



Statesville Elementary School



ADW Architects

# FACILITY PROGRAM

## ELEMENTARY SCHOOLS



Renaissance West STEAM Academy



Little Diversified Architectural Consulting

25 July 2022

## **LIST OF REVISIONS**

**See Appendix**

# TABLE OF CONTENTS

CMS ELEMENTARY SCHOOL PROGRAM OF SPACES – 45 CLASSROOMS..... 3

PRE-KINDERGARTEN CLASSROOM ..... 4

GENERAL CLASSROOM - GRADES K-1<sup>ST</sup> ..... 6

GENERAL CLASSROOM - GRADES 2<sup>ND</sup> – 5<sup>TH</sup> ..... 8

RESOURCE ROOM ..... 10

TEAM AREA ..... 11

TUTOR ROOM ..... 12

FLEX USE ROOM ..... 13

EXCEPTIONAL CHILDREN’S CLASSROOM ..... 14

MODIFIED RESTROOM ..... 16

VISUAL ARTS CLASSROOM..... 18

MUSIC/CHORAL CLASSROOM..... 21

MEDIA CENTER ..... 23

MAKERSPACE ..... 27

MULTIPURPOSE ROOM..... 28

RECEPTION / SECRETARY’S AREA..... 30

PRINCIPAL’S OFFICE..... 32

ASSISTANT PRINCIPAL’S OFFICE..... 33

FINANCIAL SECRETARY OFFICE ..... 34

ITINERANT STAFF WORK SPACE..... 35

CONFERENCE ROOM..... 36

WORKROOM..... 37

FACULTY BREAKROOM ..... 39

STUDENT RECORDS ..... 40

HEALTH ROOM ..... 41

STUDENT SERVICES OFFICE & CONF. RM..... 43

PARENT CENTER..... 44

WELLNESS ROOM – ELEMENTARY SCHOOL ..... 45

SRO OFFICE ..... 46

CAFETERIA AND KITCHEN..... 47

PLANT OPERATIONS..... 50

CUSTODIAL ROOMS ..... 51

STAFF TOILETS..... 52

OUTDOOR AREA..... 53

CORRIDOR..... 54

**CMS ELEMENTARY SCHOOL PROGRAM OF SPACES - 45 CLASSROOMS**

1/20/2022

SPACE	QTY	CMS SF	TOTAL SF
<b>GENERAL CLASSROOMS</b>			
CLASSROOMS - K-1	14	1,000	14,000
CLASSROOMS - 2-5	28	800	22,400
<b>SUBTOTAL</b>	<b>42</b>		<b>36,400</b>
<b>SUPPORT SPACES</b>			
RESOURCE ROOM	1	450	450
TEAM AREA	2	500	1,000
K-1 TOILETS	14	50	700
TUTOR ROOMS (2-5)	12	100	1,200
FLEX USE ROOM	1	250	250
BOOK STORAGE	1	400	400
MODIFIED RESTROOM	1	150	150
WELLNESS ROOM	1	200	200
<b>SUBTOTAL</b>			<b>4,350</b>
<b>ELECTIVE CLASSROOMS</b>			
VISUAL ARTS CLRM.	1	1,500	1,500
VISUAL ARTS STORAGE	1	250	250
KILN ROOM	1	95	95
MUSIC / CHORAL CLRM.	1	1,200	1,200
MUSIC / CHORAL STORAGE	1	200	200
<b>SUBTOTAL</b>			<b>3,245</b>
<b>MEDIA CENTER</b>			
MAIN USE ROOM	1	2,900	2,900
EQUIPMENT STORAGE	1	200	200
MAKERSPACE CLRM.	1	750	750
TV STUDIO	1	250	250
OFFICE	1	150	150
WORKROOM	1	200	200
<b>SUBTOTAL</b>			<b>4,450</b>
<b>PHYSICAL EDUCATION</b>			
MULTIPURPOSE ROOM	1	4,900	4,900
MULTIPURP. STORAGE	1	350	350
MULTIPURP. CHAIR STOR	1	300	300
MULTIPURP. PLATFORM	1	850	850
<b>SUBTOTAL</b>			<b>6,400</b>

INDICATES ACTUAL CLASSROOM

SPACE	QTY	CMS SF	TOTAL SF
<b>ADMINISTRATION</b>			
RECEPTION / SECRETARIAL	1	500	500
PRINCIPAL OFFICE	1	200	200
ASST. PRINCIPAL OFFICE	2	150	300
LARGE CONFERENCE	1	350	350
SMALL CONFERENCE	1	200	200
COUNSELOR OFFICE	2	150	300
COUNSELOR CONFERENCE	1	200	200
WORKROOM	1	500	500
FACULTY BREAKROOM	1	500	500
ITINERANT STAFF OFFICE	1	400	400
FINANCIAL SECR. OFFICE	1	150	150
STAFF TOILETS	2	65	130
HEALTH ROOM	1	250	250
HEALTH ROOM TOILET	1	65	65
STORAGE	1	250	250
STUDENT RECORDS	1	100	100
STUDENT SVCS. OFFICE	1	250	250
PARENT CENTER	1	250	250
SRO OFFICE	1	100	100
<b>SUBTOTAL</b>			<b>4,995</b>
<b>CAFETERIA / NUTRITION</b>			
DINING	1	4,200	4,200
SERVING	1	500	500
KITCHEN	1	2,200	2,200
FOOD SERVICE OFFICE	1	125	125
STAFF TOILET	1	65	65
STAFF LOCKER	1	75	75
<b>SUBTOTAL</b>			<b>7,165</b>
<b>BUILDING SUPPORT</b>			
MECHANICAL			3,900
ELECTRICAL			1,100
GROUP RESTROOMS	8	295	2,360
STAFF TOILETS	6	55	330
CUSTODIAL			900
IT (IDF AND MDF)			500
<b>SUBTOTAL</b>			<b>9,090</b>
<b>BUILDING SUBTOTAL</b>			<b>76,095</b>
<b>NON ASSIGNABLE</b>			
<b>CIRCULATION</b>			
<b>WALLS</b>			
<b>% OF BUILDING SUBTOTAL</b>	<b>34%</b>		<b>25,870</b>
<b>TOTAL SQUARE FOOTAGE</b>			<b>101,965</b>

# **PRE-KINDERGARTEN CLASSROOM**

## **OBJECTIVES**

- Cognitive, social, emotional and physical development are interrelated in young children, and all developmental areas must be addressed
- Each child is unique with an individual pattern of timing, growth and development
- Young children construct knowledge and understanding through their interactions with materials within their environment and through their interactions with adults and other children
- Children’s learning moves from a concrete, personal understanding to conventional understandings through awareness, exploration, inquiry and utilization
- Children have a need to make sense of their experiences and are motivated to learn by their interests and natural curiosity
- Provides an environment that encourages learning through exploration and discovery
- Recognizes that children differ in their rates of development, backgrounds, and experiences
- Establishes a partnership between parents and school staff that supports children throughout their total school experience
- Allows for the “basics” to be taught through children’s own experiences, with materials in the classroom
- Respects play for its value as an appropriate learning medium for children of this age
- Is based on research which indicates how young children learn



## **CAPACITY**

1 teacher      1 assistant

## **ACTIVITIES**

- Large and small group work
- Independent work
- Choice periods – 12 centers:
  - Library
  - Dramatic play
  - Writing
  - Listening
  - Sand and water
  - Mathematics
  - Computers
  - Science
  - Art
  - Manipulative
  - Blocks
  - Music
- Active exploration and interaction with physical environment
- Learning activities and materials primarily involve concrete, real experiences relevant to the lives of children

## **DESIGN CONSIDERATION**

- Classroom floor plan should allow large group activity as well as learning centers for specific activities
- Provide direct access to an exterior enclosed play yard and garden area– extending classroom outside

## PHYSICAL REQUIREMENTS

### Architectural Criteria

- Provide adjacent exterior, fenced play area. Fence to be 48" minimum height with non-locking gate latches. Desired exterior elements include covered play space, and both hardscape play area and "soft" play area
- Floor: Provide VCT
- Ceiling height should be 10' minimum
- Ceiling: Provide acoustical tile
- Windows: Provide sill height 24"-26" AFF with 1" mini-blinds typical
- Doors: PK to have direct access to outdoors. Interior doors to corridors are to include a 3" wide vision panel. Walls: Provide painted gypsum wallboard, pre-cast concrete or CMU
- Account for a location of small refrigerator within the school

### Mechanical Criteria

- Individual (single WC) toilet room at each classroom with floor drain and lavatory within individual toilet room – hot (tempered) and cold water to be provided
- Provide 24" base cabinet with countertop and sink in classroom w/hot (tempered) and cold water
- Provide plaster trap at classroom sink
- Provide CO monitor in each classroom
- Provide HVAC wall temperature sensor in each classroom

### Electrical Criteria

- Provide Teaching Wall per detail in A/E Guide.
- Provide duplex outlets with covers every 8' on center
- Provide switched controls to provide multiple levels of lighting from ceiling fixtures— One switch for inboard lamps at each fixture, a second switch for outboard lamps at each fixture, both located near the classroom entry door off the corridor. Provide a third switch to control the single row of light fixtures nearest the Teaching Wall. Third switch to be located near the Teaching Wall.
- Provide natural light in compliance with state kindergarten facility
- Provide intercom/phone with volume control and privacy feature
- Provide computer network drops and power outlets per A/E Guide appendix
- Provide all outlets for computers on separate circuit

### Furniture and Fixtures

- Provide mirror 3' wide x 5' high near classroom wet area for viewing by students
- Provide markerboards and tackboards at Teaching Wall per detail in A/E Guide
- Tack strips above marker board should accommodate 4 map/chart holders, 4 hooks, and base for 2 flag holders
- Provide two 48"x84" high lockable storage cabinets
- 16' base cabinets with sink to be a mix of drawers, closed, lockable, and open shelf storage units.
- Provide 24-26 open-faced individual cubbies 12" wide x 12" deep. Total height of cabinet 60"
- Provide wall cabinet 84"-72" high x 18" deep to 22" deep x 32" wide to 36" wide w/lock and adjustable shelving
- Provide paper cabinet 5 shelves to hold 24" x 36" paper
- Provide area rugs for floor play

# **GENERAL CLASSROOM - GRADES K-1<sup>ST</sup>**

## **OBJECTIVES**

To provide Kindergarten through First Grade students and educators an environment that is inviting, stimulating, and student centered. The program should accommodate a variety of activities that provide learning experiences that are interactive, experiential, and holistic. It should stimulate intellectual, social, and emotional growth enabling students to become effective, responsible citizens.



## **CAPACITY**

1 teacher

1 teacher assistant

## **ACTIVITIES**

- Large and Small group instruction to include reading, writing, math and science, as well as technology, and multi-media exploration, and student performances.
- Integration of all core curriculum subjects
- Encouragement through independence and personal responsibility is highlighted within flexible learning areas, display and board space, as well as student storage areas

## **DESIGN CONSIDERATIONS**

- K-1 classrooms should be easily accessible from the bus parking area/paved play space, and parent pick-up/drop-off area as well as administration offices and cafeteria, media center, multi-purpose room/gym, art and music classrooms.
- K-1 classrooms must be located on a level of exterior exit discharge and should be grouped together. Each classroom is to have a direct access to the exterior of the building and an adjacent play space that includes an area of non-vegetated earth for manipulation in various ways

## **PHYSICAL REQUIREMENTS**

### Architectural Criteria

- Floor: Provide VCT or rolled rubber with heat welded seams
- Ceiling height should be 10' minimum
- Ceiling: Provide acoustical tile
- Windows: Provide sill height 24"-26" AFF with 1" mini-blinds typical
- Doors: K-1 to have direct access to outdoors. Interior doors to corridors are to include a 3" wide vision panel.
- Walls: Provide painted gypsum wallboard, pre-cast concrete or CMU

### Mechanical Criteria

- Individual (single WC) toilet room at each classroom with floor drain and lavatory within individual toilet room – hot (tempered) and cold water to be provided
- Provide 24" deep base cabinets with countertop and stainless steel sink in classroom w/hot (tempered) and cold water
- Provide plaster trap at classroom sink
- Provide CO monitor in each classroom
- Provide HVAC wall temperature sensor in each classroom

### Electrical Criteria

- Provide Teaching Wall per detail in A/E Guide.
- Provide duplex outlets with covers every 8' on center
- Provide switched controls to provide multiple levels of lighting from ceiling fixtures– One switch for inboard lamps at each fixture, a second switch for outboard lamps at each fixture, both located near the classroom entry door off the

corridor. Provide a third switch to control the single row of light fixtures nearest the Teaching Wall. Third switch to be located near the Teaching Wall.

- Provide natural light in compliance with state kindergarten facility
- Provide intercom/phone with volume control and privacy feature
- Provide computer network drops and power outlets per A/E Guide appendix
- Provide all outlets for computers on separate circuit

### Furniture, Fixtures and Equipment

- Provide markerboards and tackboards at Teaching Wall per detail in A/E Guide
- Provide built in base cabinets with plastic laminate countertop and stainless steel sink near toilet room
- Provide paper storage cabinet - 5 open shelves to hold 24" x 36" paper
- Provide teacher coat closet w/lock 36" wide x 24" deep x 88" high
- Provide wall cabinets with adjustable shelving
- Towel dispenser and liquid soap dispenser to be installed on wall above base cabinet near sink
- Provide enclosed wardrobe cabinets with a total of 24-26 (minimum) coat hooks spaced no closer than 12" o.c. Provide 24-26 (minimum) open-faced individual cubbies 12" wide x 12" high x 12" deep. Total height of wardrobe/cubbies cabinet 60".
- Provide one 4' x 8' tack board near each classroom door in the corridor –top of tack board to be 6'-0" AFF

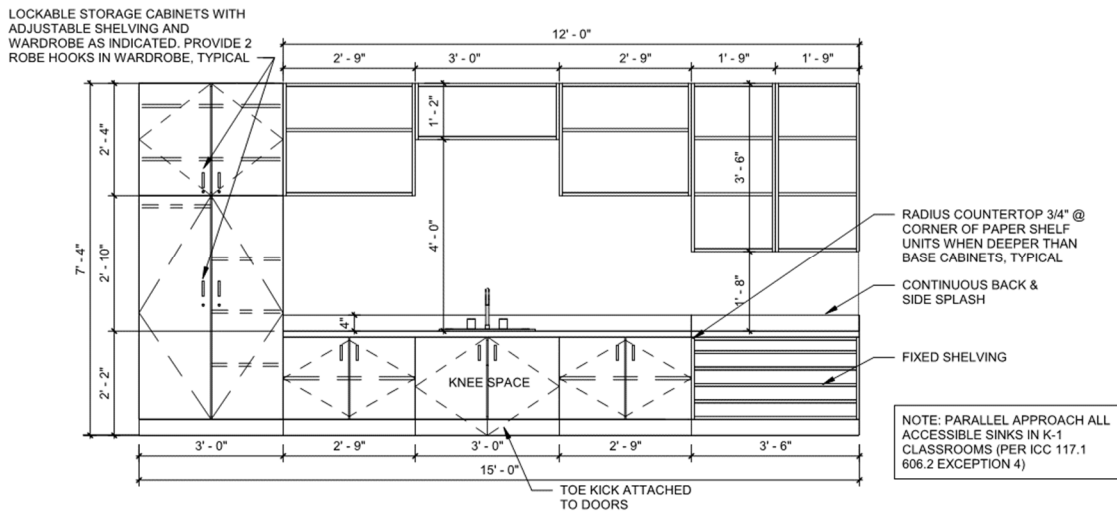

### CASEWORK ELEVATION - K-1 CLASS

1/4" = 1'-0"

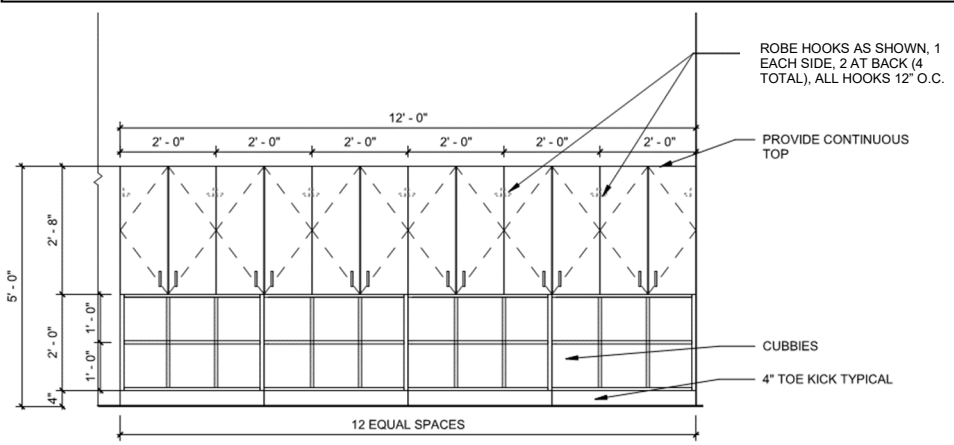

### CASEWORK ELEVATION - CLASSROOM CUBBIES

1/4" = 1'-0"



# **GENERAL CLASSROOM - GRADES 2<sup>ND</sup> – 5<sup>TH</sup>**

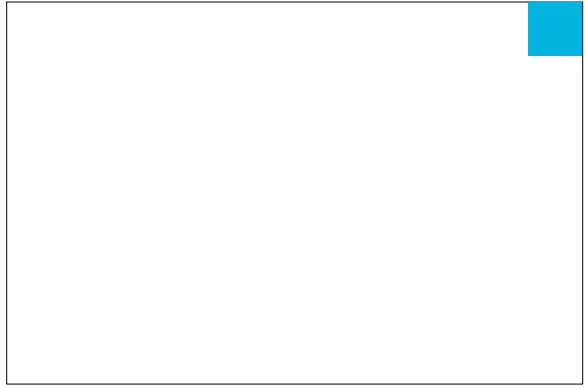

## **OBJECTIVES**

To provide Second through Fifth grade students and educators an environment that is inviting, stimulating, and student centered. The program should accommodate a variety of activities that provide interactive learning experiences, experiential activity, and holistic learning. It should stimulate intellectual, social, and emotional growth enabling students to become effective, responsible citizens.

## **CAPACITY**

1 teacher

1 teacher assistant

## **ACTIVITIES**

- Large and Small group instruction to include reading, writing, math and science, as well as technology, and multi-media exploration, and student performances.
- Integration of all core curriculum subjects
- Encouragement through independence and personal responsibility is highlighted within flexible learning areas, display and board space, as well as student storage areas

## **DESIGN CONSIDERATIONS**

- 2-5 grade classrooms should be easily accessible from the administration offices and cafeteria, media center, multi-purpose room/gym, art and music classrooms
- Tutor rooms should be located on main corridors and adjacent to and between classrooms to allow one tutor room to be shared by two classrooms

## **PHYSICAL REQUIREMENTS**

### Architectural Criteria

- Floor: Provide VCT or rolled rubber with heat welded seams
- Ceiling height should be 10' minimum
- Ceiling: Provide acoustical tile
- Windows: Provide sill height 24"-26" AFF with 1" mini-blinds typical
- Doors: Interior doors to corridors are to include a 3" wide vision panel.
- Walls: Provide painted gypsum wallboard, pre-cast concrete or CMU

### Mechanical Criteria

- Provide 24" deep base cabinets with countertop and stainless steel sink in classroom w/hot (tempered) and cold water
- Provide CO monitor in each classroom
- Provide HVAC wall temperature sensor in each classroom

### Electrical Criteria

- Provide Teaching Wall per detail in A/E Guide.
- Provide duplex outlets with covers every 8' on center
- Provide switched controls to provide multiple levels of lighting from ceiling fixtures– One switch for inboard lamps at each fixture, a second switch for outboard lamps at each fixture, both located near the classroom entry door off the corridor. Provide a third switch to control the single row of light fixtures nearest the Teaching Wall. Third switch to be located near the Teaching Wall.
- Provide intercom/phone with volume control and privacy feature
- Provide computer network drops and power outlets per A/E Guide appendix

- Provide all outlets for computers on separate circuit

**Furniture, Fixtures and Equipment**

- Provide markerboards and tackboards at Teaching Wall per detail in A/E Guide
- Provide built-in base cabinets with plastic laminated countertop and stainless steel sink
- Provide paper storage cabinet - 5 open shelves to hold 24" x 36" paper
- Provide teacher coat closet w/lock 36" wide x 24" deep x 88" high
- Provide wall cabinets with adjustable shelving
- Towel dispenser and liquid soap dispenser to be installed on wall above base cabinet near sink
- Provide enclosed wardrobe cabinets with a total of 24-26 (minimum) coat hooks spaced no closer than 12" o.c. Provide 24-26 (minimum) open-faced individual cubbies 12" wide x 12" high x 12" deep. Total height of wardrobe/cubbies cabinet 60".
- Provide one 4' x 8' tack board in hallway near the classroom door. Top of tack board to be at 6' AFF.

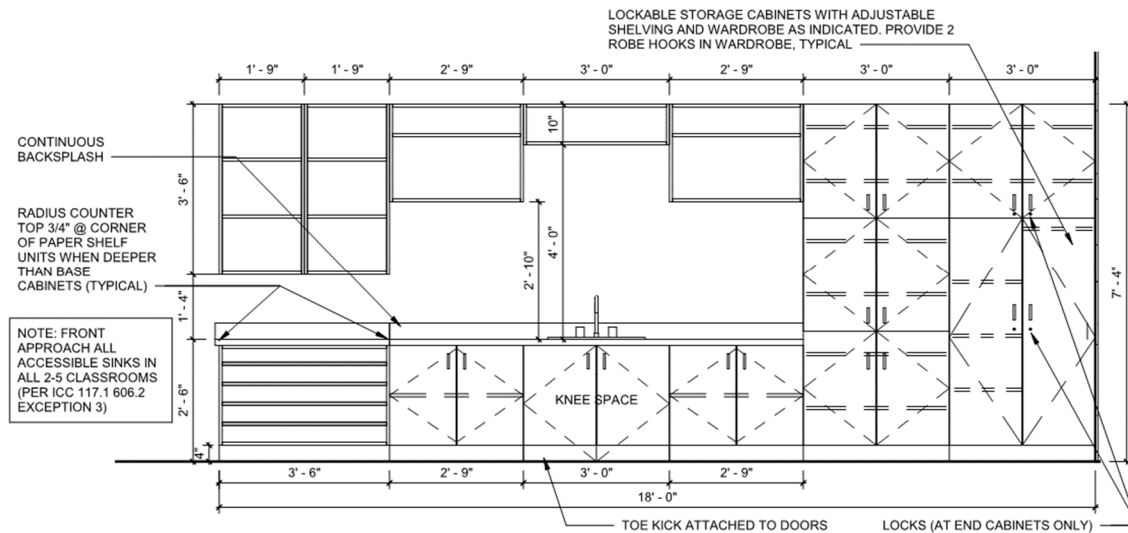

**CASEWORK ELEVATION - 2-5 CLASSROOMS**

1/4" = 1'-0"

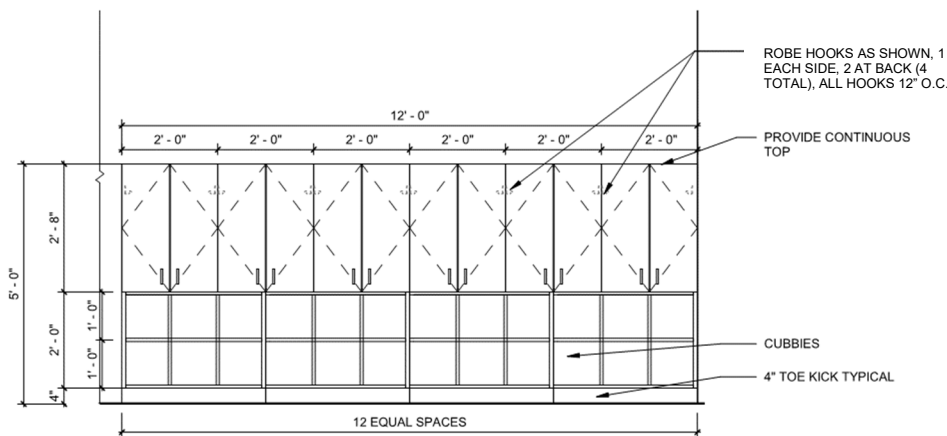

**CASEWORK ELEVATION - CLASSROOM CUBBIES**

1/4" = 1'-0"

# RESOURCE ROOM

## OBJECTIVES

To provide an additional space for any activity that is conducted with less than a full classroom of students.

## CAPACITY

1 teacher

## DESIGN CONSIDERATIONS

Resource rooms should be integrated with grade level classroom areas.

## PHYSICAL REQUIREMENTS

### Architectural Criteria

- Floor: Provide VCT or rolled rubber with heat welded seams
- Ceiling height should be 9' minimum
- Ceiling: Provide acoustical tile
- Windows: Provide sill height 24"-26" AFF with 1" mini-blinds typical
- Doors: Interior doors to corridors are to include a 3" wide vision panel.
- Walls: Provide painted gypsum wallboard, pre-cast concrete or CMU

### Mechanical Criteria

- Provide 24" deep base cabinets with countertop and stainless steel sink w/hot (tempered) and cold water
- Provide CO monitor
- Provide HVAC wall temperature sensor

### Electrical Criteria

- Provide Teaching Wall per detail in A/E Guide.
- Provide duplex outlets with covers every 8' on center
- Provide intercom/phone with volume control and privacy feature
- Provide computer network drops and power outlets per A/E Guide appendix
- Provide all outlets for computers on separate circuit

### Furniture, Fixtures and Equipment

- Provide markerboards and tackboards at Teaching Wall per detail in A/E Guide
- Provide built-in base cabinets with plastic laminated countertop and stainless steel sink
- Provide wall cabinets with adjustable shelving
- Towel dispenser and liquid soap dispenser to be installed on wall above base cabinet near sink
- Provide one 4' x 8' tack board in hallway near the classroom door. Top of tack board to be at 6' AFF.

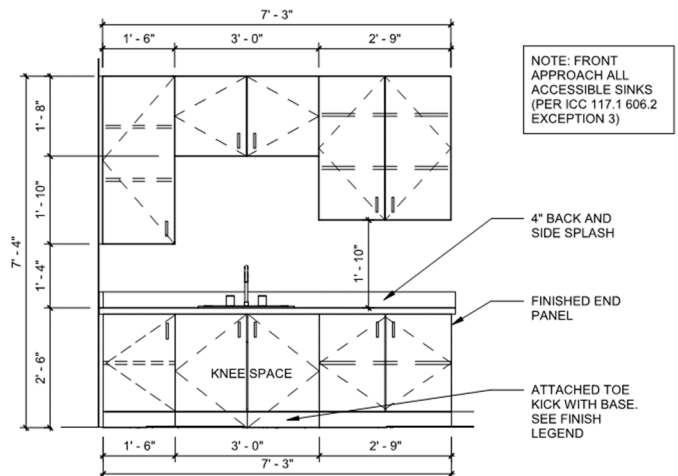
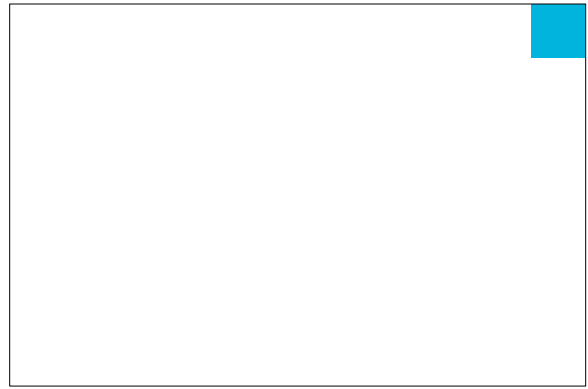

## CASEWORK - RESOURCE

1/4" = 1'-0"

# TEAM AREA

## OBJECTIVES

To provide a private area for the preparation of materials and planning of team issues and for the storage of supplies

## CAPACITY

4-16 People

## ACTIVITIES

Team teachers engaged in conferencing, scheduling and planning strategies for students and conferences with parents.

## DESIGN CONSIDERATIONS

One team area located in close proximity to each grade level classroom wing

## PHYSICAL REQUIREMENTS

### Architectural Criteria

- Provide a designated area for a copier in the Team Area that is close to the door to be easily accessible from the corridor.
- Provide base and wall cabinets along one wall in the room with a sink. Cabinets to be a combination of closed, open shelf and drawer units.
- Provide 4'x8' markerboard
- Provide 4'x8' tack board
- Provide 1" mini-blinds for windows
- Provide upright residential-size refrigerator (include in GC contract), coordinated with casework.

### Electrical Criteria

- Provide network connection for wall-mounted promethean board.
- Provide duplex outlets with covers every 8' on center.
- Provide intercom/phone with volume control and privacy feature.
- Provide computer network drops and power outlets per A/E Guide appendix.
- Provide (2) network drops and power for copier.
- Provide power for refrigerator.

### Furniture, Fixtures and Equipment

- Conference Table

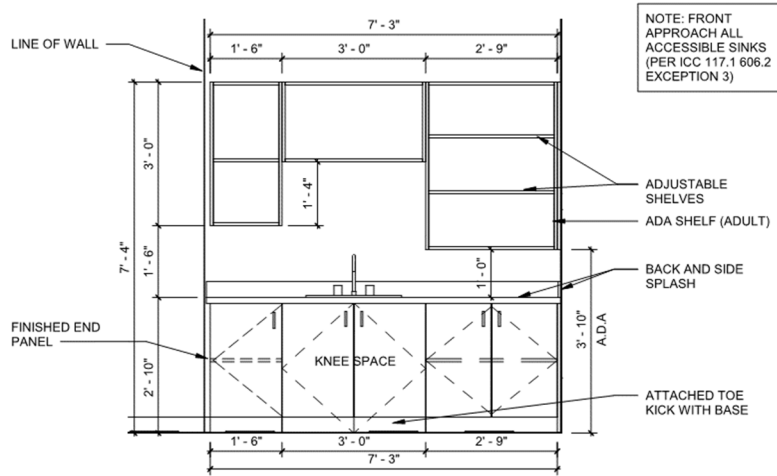
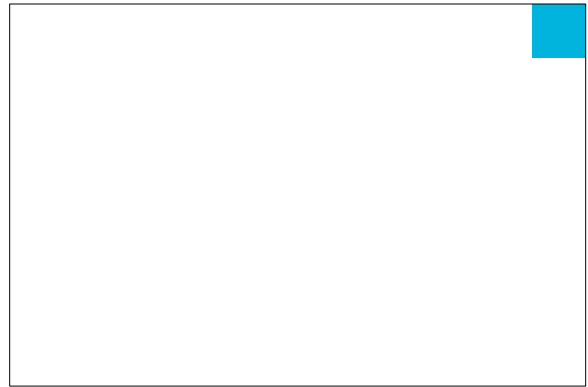

CASEWORK ELEV. - TEAM

1/4" = 1'-0"

# **TUTOR ROOM**

## **OBJECTIVES**

To provide a flexible space for individual pull-out instruction, teacher planning, and parent observations, associated with the 2<sup>nd</sup> – 5<sup>th</sup> grade classrooms.

## **CAPACITY**

Two to four persons

## **ACTIVITIES**

- Planning
- Individual instruction
- Minor student time out
- Parent observation of class activities
- Small group instruction
- Conferencing

## **DESIGN CONSIDERATIONS**

Locate-tutor room between two classroom spaces to be shared by both

## **PHYSICAL REQUIREMENTS**

- Provide one way glass vision panel between tutor room and each classroom
- Each vision panel to be equipped with 1" mini-blinds (on interior)
- Provide one computer outlet paired with a quad electrical outlet
- Provide intercom connection
- Provide duplex electrical outlets located around the room at 6' on center
- Provide carpeted floor
- Provide automatic motion sensors to control ceiling light fixture
- Provide 4'x4' markerboard

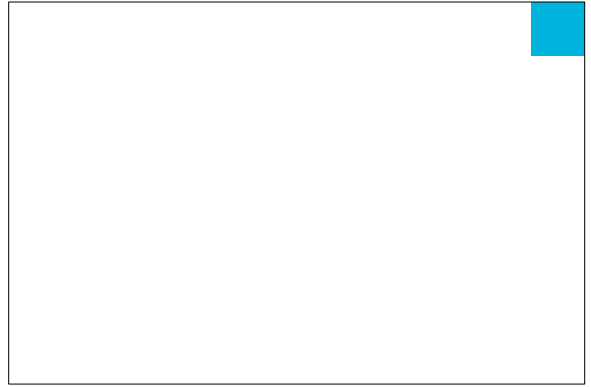

# FLEX USE ROOM

## OBJECTIVES

To provide a smaller flexible teaching space for the whole building. The Flex Use Room will provide classroom extension, itinerant activity space and small group pull-out ability. The actual use of the space will be coordinated among the grade level teachers.

## CAPACITY

Varies

## ACTIVITIES

- Small group instruction
- Teaching stations
- One-on-one pull out

## PHYSICAL REQUIREMENTS

### Architectural Criteria

- Floor: Provide VCT or rolled rubber with heat welded seams
- Ceiling height should be 9' minimum
- Ceiling: Provide acoustical tile
- Windows: Provide sill height 24"-26" AFF with 1" mini-blinds typical
- Doors: Interior doors to corridors are to include a 3" wide vision panel.
- Walls: Provide painted gypsum wallboard, pre-cast concrete or CMU

### Mechanical Criteria

- Provide CO monitor in each classroom
- Provide HVAC wall temperature sensor in each classroom

### Electrical Criteria

- Provide Teaching Wall per detail in A/E Guide.
- Provide computer network drops and power outlets per A/E Guide appendix
- Provide duplex outlets with covers every 6' on center
- Provide intercom/phone with volume control and privacy feature
- Provide computer network drops and power outlets per A/E Guide appendix
- Provide all outlets for computers on separate circuit

### Furniture, Fixtures and Equipment

- Provide markerboards and tackboards at Teaching Wall per detail in A/E Guide
- Provide built-in base cabinets with plastic laminated countertop and stainless steel sink
- Provide wall cabinets with adjustable shelving
- Towel dispenser and liquid soap dispenser to be installed on wall above base cabinet near sink

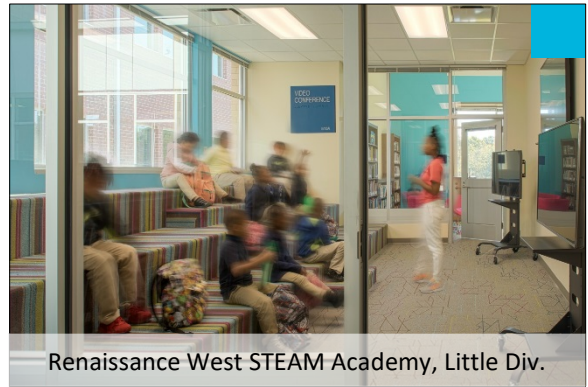

Renaissance West STEAM Academy, Little Div.

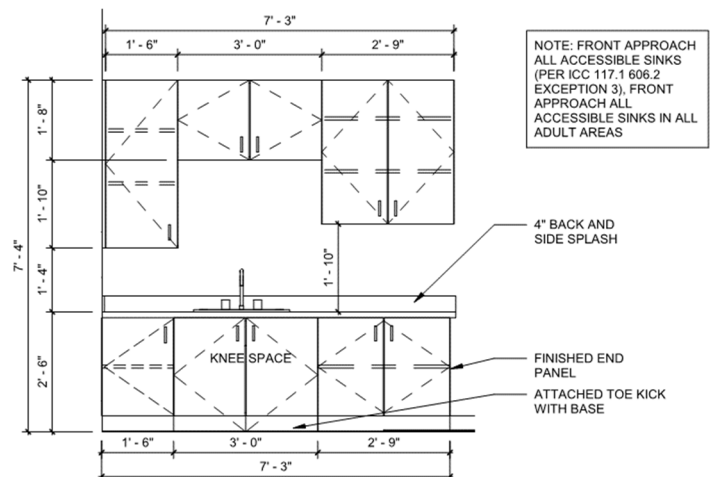

## CASEWORK - FLEX

1/4" = 1'-0"

# **EXCEPTIONAL CHILDREN'S CLASSROOM**

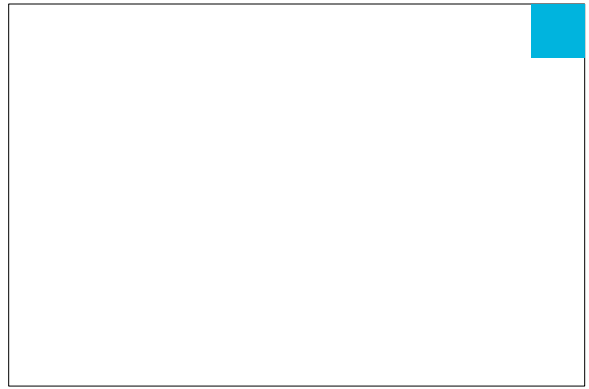

## **OBJECTIVES**

The purpose of Exceptional Children programs is to provide a continuum of services to students with disabilities ages 3-21 so that they may achieve to the maximum extent possible in the least restrictive environment appropriate to meet their needs. To that end, Exceptional Children programming promotes:

- Providing special education services to exceptional children in regular classrooms with non-disabled peers to the maximum extent possible, as appropriate.
- Providing a full continuum of programs and services to help all students achieve to their highest potential.
- Providing related services such as speech therapy and occupational and physical therapy in inclusive learning environments which support the individualized educational program.
- Providing modifications/adaptations to regular education curriculum
- Teaching students using varied learning styles.
- Creating individualized education programs for each identified student.

## **CAPACITY**

1 teacher, 1 assistant, and possibly a physical therapist (The type of EC program will determine the number of students assigned.)

## **DESIGN CONSIDERATIONS**

Exceptional Children programs should be integrated with the general classrooms.

## **PHYSICAL REQUIREMENTS**

Refer to "**Department of Public Instructional Exceptional Children Facilities Planner**" for specific facility design requirements. This document is located in the A&E Guide.

### Architectural Criteria

- Locate classrooms on main level, each connected to an adjacent modified restroom, or with modified restroom between two classrooms. If two restrooms provided, prefer to place one restroom with each EC classroom, dispersed into separate areas of building, including second floor.
- Locate classroom near Cafeteria, Media Center, Auditorium.
- Classrooms are to be standard size, 750 square feet. Classrooms are not special in design, and could be used for general population as well.
- Must accommodate students in wheelchairs. Students served could include autism, cerebral palsy, cognitive issues, physical disabilities, muscular dystrophy.
- Provide wireless access point.
- Refer to Teaching Wall detail in A/E Guide.
- Provide vinyl tile floor finish.

### Mechanical Criteria

- Mechanical system needs to be quiet.

### Electrical Criteria

- Lighting in classroom will need particular attention to color of light (blue). Consider programmable LEDs for color variation in classrooms.
- Provide cabling in ceiling for classroom camera.

- Provide cabling in ceiling for wireless access point.
- Provide intercom/phone with volume control and privacy feature.



## **MODIFIED RESTROOM**

### **OBJECTIVES**

To provide adequate space for toileting and clothes changing area for students needing personal hygiene care under the supervision of a designated adult. The modified restroom is not intended to meet the requirements or fixture counts for ADA accessible restrooms.

### **CAPACITY**

1-3 people

### **RELATIONSHIPS**

- Option 1 (preferred): Located ground level between (2) classrooms and near a main corridor, with corresponding doors to both classroom(s) and to the corridor required.
- Option 2: Located ground level adjacent to (1) classroom, with doors to the classroom and the corridor.
- If two restrooms provided, prefer to place one restroom with each EC classroom, dispersed into separate areas of building, including second floor.

### **ACTIVITIES**

- Toileting, showering, bathing.
- Storage (first aid supplies, linens for beds).
- Teaching life skills.
- Inclusive practices.

### **PHYSICAL REQUIREMENTS:**

#### Architectural Criteria

- Ceramic tile walls to ceiling, and slip resistant floor tile.
- Wall mounted swing up Grab Bars for toilet, Elementary/K8 30"-32" height, Middle/High 35"-36" height. Length 29 inches at both rails.
- Free rolling toilet paper holder (preferred location on wall mounted swing up grab bars).
- Paper towel and liquid soap dispensers at lavatory.
- Mirror located 1"-2" above sink.
- Soap Dispenser - locate 1"-2" from edge of sink with bottom edge 2" above sink.
- Paper Towel Dispenser – locate opposite soap dispenser 2"-3" from edge of sink with bottom 3"-4" above sink.
- Doors swinging outward to the adjacent classrooms. Door swinging inward from corridor.
- Locks at all doors (thumb turn on bathroom side and key on classroom/hallway side). Accessible lever handles. Locksets to be privacy set with Vacant/Occupied indicator.
- 30"x30" clear floor space to accommodate adaptive toilet seat storage.
- Signage to read "Modified Restroom" (no ADA accessible signage).
- Floor mounted storage cabinet with countertop, shelves and doors, 36" high x 36"-40" wide x 15" deep, with one section lockable for cleaning supplies, and wall cabinet above of matching width, with shelves and doors.
- Space for metal foot-activated trash can, 12 gallon size.
- No curtain required in restroom.

#### Mechanical Criteria

- Warm/cold water accessible shower w/ hand held shower head.



- Wall mounted sink, tempered/hot water and cold water, standard basin (not elongated) w/ gooseneck faucet with automatic meter for water flow, and 18" clear space both sides, Elementary/K8 29"-31" to rim of sink, Middle/High 34" to rim of sink, 27"-28" to underside of sink basin.
- Scald protection around exposed drainage piping.
- Toilet located center of the wall, Elementary K-1 grades 12"-13" seat height, 2-5 grades 13"-14" seat height, Middle/High 15"-17" seat height.
- Hose bib.
- Adequate ventilation to disperse odors.

Electrical Criteria

- Duplex outlets as required by code.
- Hospital grade electrical outlet 8"-10" AFF and outside the footprint of the changing table to prevent damage to the table and cord during high/low table operation.
- Intercom with volume control and privacy switch located near toilet, and ceiling mounted speaker.

Furniture, Fixtures and Equipment

- Space for Changing Table (Performa X-Frame Hi-Lo Changing Table) 72"x25" for Middle/High, 60"x25" for Elementary. Adjustable height table.

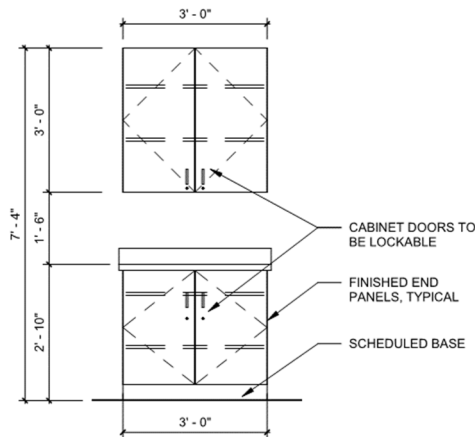

CASEWORK ELEVATION - MODIFIED RESTROOM

1/4" = 1'-0"

# **VISUAL ARTS CLASSROOM**

## **OBJECTIVES**

To Provide a Visual Arts classroom for the 21st Century that is reflective of the changing world around us. Students are engaged in learning, both individually and collaboratively how to visually communicate their thoughts with a variety of tools and media. Visual Arts education includes studio production, art history, aesthetics and art criticism. The course of study follows National Art Standards, North Carolina Standard Course of Study and Framework for 21st Century Learning. The environment should lend itself to flexibility, creativity, and problem solving and contain current resources for students.

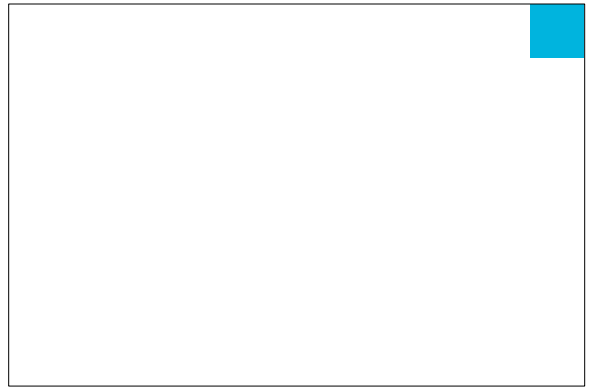

## **CAPACITY**

1 teacher                      35 students

## **ACTIVITIES**

Students create art using skills developed in:

- Drawing
- Painting
- Printmaking
- Collage
- Textiles
- Ceramics
- Sculpture
- Fibers

Resources used include prints, texts, digital images, and internet resources.

## **DESIGN CONSIDERATIONS**

- Students create art in both 2-D and 3-D format. Space is required to create art and space is required for necessary storage.
- Storage for art materials is paramount. Teachers must have ample storage for the wide variety of materials required to complete the Standard Course of Study. There are specific tools for each medium that need to be stored between each year's use.
- In addition to student work space, countertops, and storage, there must be floor space provided for the standard visual arts equipment. See list of equipment under Furniture, Fixtures and Equipment below.
- Visual resources, including prints, textbooks, digital images and websites are frequently used by the teacher and must be accessible for up-to-date instruction in visual arts. Storage for these items must also be available in the classroom.
- Visual Arts Education is available to all students in the school, which includes any exceptional students.
- Relation to entries: Location on the first floor at the end of a corridor is ideal for easy exit and noise isolation. An exit door located from the art room onto an exterior patio will be utilized if provided.
- Provide kiln room accessible from classroom.

## **PHYSICAL REQUIREMENTS**

Architectural Criteria

- Floor: Provide VCT floor finish
- Ceiling height should be 10' minimum
- Ceiling: Provide acoustical tile
- Windows: Provide sill height 24"-26" AFF with 1" mini-blinds typical

- Doors: Interior doors to corridors are to include a 3" wide vision panel.
- Walls: Provide painted gypsum wallboard, pre-cast concrete or CMU
- Provide markerboards and tackboards at Teaching Wall per detail in A/E Guide.
- Provide built-in base cabinets with plastic laminated countertop and stainless steel sink.
- Provide wall cabinets with adjustable shelving.
- Towel dispenser and liquid soap dispenser to be installed on wall above base cabinet near sink.
- Provide cabinet with 15 sliding shelves.
- Provide 36" deep base cabinet with minimum 36" clear above for paper cutter located away from sink.
- Provide as much 24" deep shelving as possible in storage room.
- Provide space for one 2'x3' cart and one slab roller in the kiln room.
- Provide lockable display cases near front office.
- Provide open adjustable shelving above all base cabinets.
- Provide one lockable storage cabinet 42"W x 88"H x 26"D.
- Provide one 4' x 8' tack board in hallway near the classroom door. Top of tack board to be at 6' AFF.
- Provide 1 kiln.
- Provide space for Furniture, Fixtures and Equipment per FF&E list below.

#### Mechanical Criteria

- Provide stainless steel scullery sink 18-22" with sidebar and plaster trap
- Provide 1-2 stainless steel hand wash sinks with plaster traps
- Provide hot and cold water to all sinks
- Size ventilation in Kiln Room to discharge excessive heat created by the kiln

#### Electrical Criteria

- Provide Teaching Wall per detail in A/E Guide.
- Provide additional duplex outlets minimum of two per wall – coordinate mounting height casework
- Provide ability to dim lights
- Provide intercom/phone with volume control and privacy feature
- Provide computer network drops and power outlets per A/E Guide appendix
- Provide all outlets for computers on separate circuit

#### Furniture, Fixtures and Equipment – by Owner

##### Visual Arts Classroom

- Provide shelving for 180 textbooks at 1" each.
- Provide (9) art tables (four legs) 4 students, 48" x 60"
- Provide (1) Ingento heavy duty paper cutter, 30" x 30"
- Provide (1) heavy duty drying rack, all steel, 30"d x 36"w x 60"h
- Provide (1) slab roller, 27"w x 52"l x 40"h
- Provide (2) rack – stack (Art), 32"w x 24"d x 32"h

##### Kiln Room

- Provide (1) cart – Brent Ware, 35"w x 24"l x 60"h
- Provide (1) clay dolly, 24"w x 24"l x 36"h

##### Art Storage Room

- Provide (1) Rubbermaid cart 24"w x 40"l x 31"h

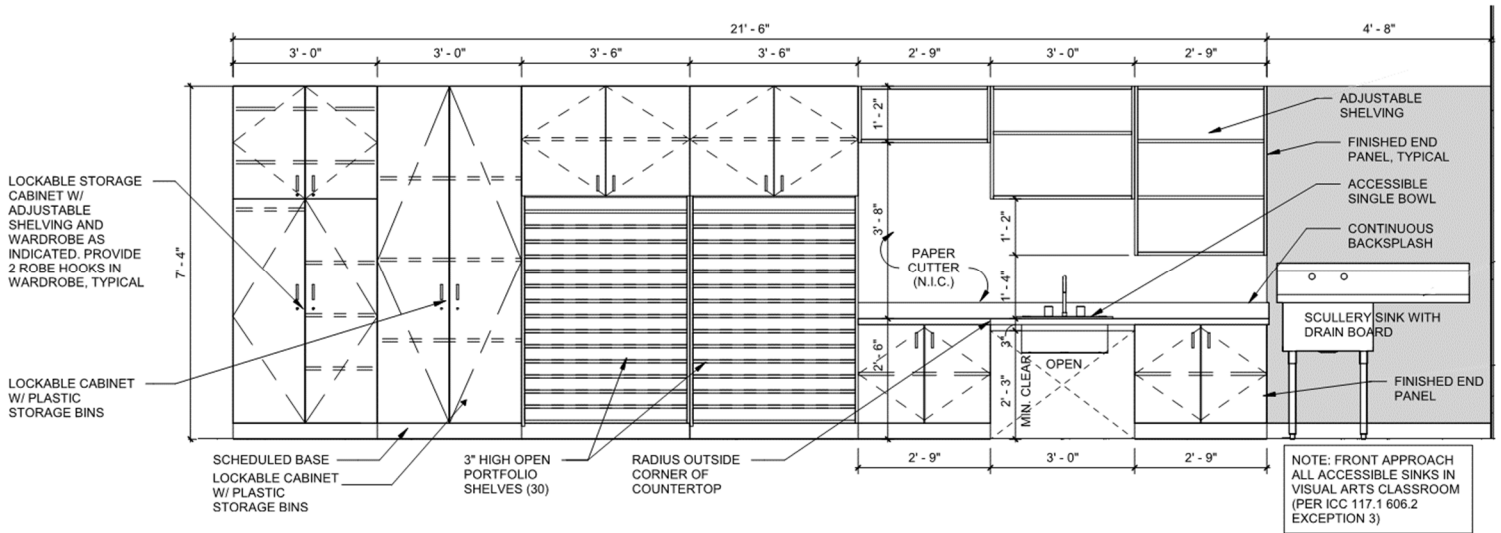

### CASEWORK ELEVATION - VISUAL ART RM

1/4" = 1'-0"

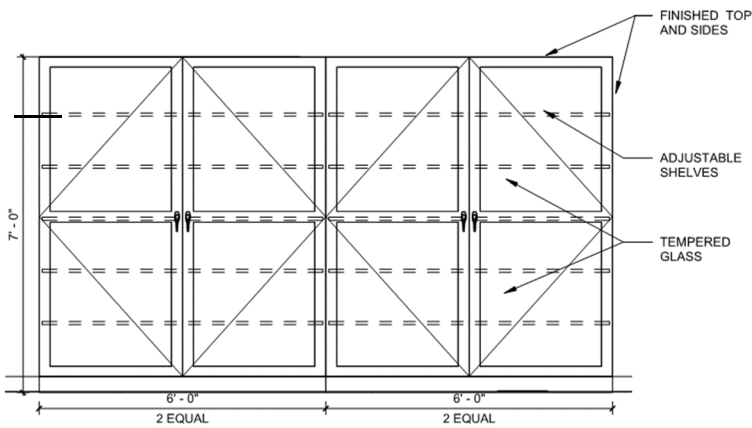

### CASEWORK ELEVATION - LOCKABLE DISPLAY CASES

1/4" = 1'-0"

# **MUSIC/CHORAL CLASSROOM**

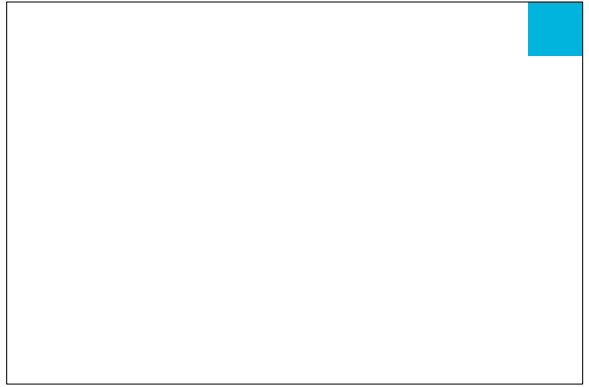

## **OBJECTIVES**

Music instruction in the elementary school involves a variety of physical and musical activities. Students dance, sing, and play instruments. They may be seated on the floor, seated in chairs, standing on risers, marching around the room organized in large or small circles. The North Carolina Standard Course of Study (NCSCOS) includes music goals and objective that parallel national standards and includes strands of learning through creating, performing, responding, and understanding music. The music classroom is a very “active” environment.

## **CAPACITY**

1 teacher      35 students      One (1) upright piano

## **ACTIVITIES**

- A typical elementary music class will engage in singing, playing instruments, moving to music, reading music, creating music and listening to music.
- Space is required for large group, small group, and individual activities.
- The room must accommodate Orff instruments, sound equipment (Bluetooth speaker, etc.) a piano, computer and video equipment.

## **DESIGN CONSIDERATIONS**

- The music teacher works cooperatively with core curriculum teachers in supporting the total elementary curriculum.
- Having easy access to the stage or performing areas will support preparation for performances.
- The frequent use of movement and sound associated with musical activities should be considered in the location of the music room. Acoustical insulation and sound abatement with a high NCR to be installed in walls and ceiling. Walls/partitions to extend to the underside of the deck above, typical.
- The music room should be designed to accommodate chairs and physical movement.
- Located near the visual arts room with easy access to the stage.
- A “Square” room would accommodate elementary music education better than a rectangular room; provide a square area in the middle of the room for group activities.
- Music room should be configured and equipped as a general classroom with base cabinet, sink and standard Teaching Wall.
- Convenient access to a water fountain should be provided.

## **PHYSICAL REQUIREMENTS**

### Architectural Criteria

- Provide VCT floor finish in the classrooms and in the storage room.
- Provide appropriate acoustical properties, good ventilation, and adequate lighting.
- Provide a separate room for lockable storage for necessary materials and classroom instruments is required and should be directly accessible to the music/choral room. Provide adjustable shelving. Owner to provide current “Performing Arts Equipment List” for use in planning for storage needs of loose music equipment and instruments.
- Provision should be made for darkening the room for use of audiovisuals (1” mini blinds).
- Provide secured general storage space for necessary materials, equipment, and classroom instruments.
- Ceiling height should be 10’ minimum; 12’ – 16’ is preferred.
- Provide exterior windows.
- Provide space for one upright Piano.

- Provide (2) 48"x88" high lockable storage units.
- Provide 4'x8' tack board.
- Provide one white dry-erase board with permanent music staff lines (Wenger #172B111, 4 ft. x 8 ft.) located at Teaching Wall.
- Provide built-in cabinets for storing hand held instruments (Wenger type, optional).
- Provide 24" and 18" deep shelves in the storage room.
- Provide cork strips with hooks and clips for display purposes.
- Provide space for Furniture, Fixtures and Equipment per FF&E list below.

**Electrical Criteria**

- Provide Teaching Wall per detail in A/E Guide.
- Provide duplex outlets with covers every 8' on center.
- Provide switched controls to provide multiple levels of lighting from ceiling fixtures– One switch for inboard lamps at each fixture, a second switch for outboard lamps at each fixture, both located near the classroom entry door off the corridor. Provide a third switch to control the single row of light fixtures nearest the Teaching Wall. Third switch to be located near the Teaching Wall.
- Provide intercom/phone with volume control and privacy feature.
- Provide computer network drops and power outlets per A/E Guide appendix.
- Provide all outlets for computers on separate circuit.

**Furniture, Fixtures and Equipment – by Owner**

**Music/Choral Classroom**

- Provide one upright Piano.
- Provide shelving for 180 textbooks at 1" each.
- Provide lockable teacher wardrobe 24"x 72" high.

**Music Storage Room**

- Provide Bass Xylophone, 20"H x 24"D x 36"W.
- See Appendix at end of this ES Facility Program for list of music instruments to be provided by Owner; Architect to provide appropriate/adequate storage for the instruments listed.

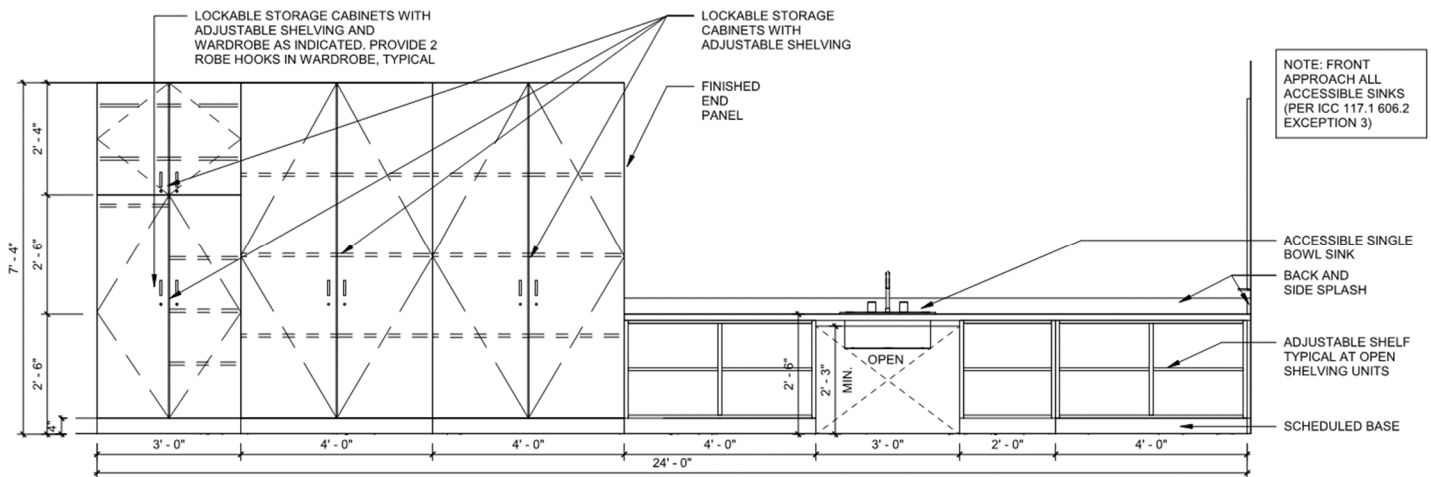

**CASEWORK ELEVATION - MUSIC**

1/4" = 1'-0"

## **MEDIA CENTER**

### **OBJECTIVES**

To provide a dynamic and essential physical and virtual space for personalized learning, knowledge construction, and academic achievement through the 21<sup>st</sup> century media center. To provide an information and knowledge space where students develop the necessary information and technology literacy skills to enable them to innovate and create new knowledge. The media center stimulates collaboration, communication, critical thinking, questioning and creativity through project-based authentic learning opportunities.



The resources must be current, multi-perspective, multi-formatted, and aligned with the American Association of School Librarians *Standards for the 21<sup>st</sup> Century Learner*, North Carolina Department of Public Instruction academic content standards, Charlotte-Mecklenburg Schools Strategic Goals 2018, and guidelines from Virtual Learning and Media Services.

The infrastructure in all areas of the media center should provide “state of the art” technology infrastructure for students to inquire, think critically, draw informed conclusions, and apply knowledge to new situations. The tools needed to organize, share, and produce this knowledge in a safe online environment community should be readily accessible to everyone in the school learning community.

### **CAPACITY**

4-6 sq. ft. per student

### **ACTIVITIES**

MAIN-USE ROOM- Must allow visibility from the circulation desk to all areas within the main room; e.g., primary storytelling area, instructional class spaces, individual and small group collaborative spaces, leisure reading and entry doors to the room.

- **Storytelling Area** (ES) should include elements that stimulate and encourage the learning process for early learners. It should be located away from the heavy traffic flow and near the low shelving specifically designed for easy/picture books. This area should be flexible to provide space for different purposes and groupings. A presentation system and story rug should be furnished for this area
- **Instructional Space** is needed for small and large groups (up to two classes simultaneously) since a major emphasis of the media center is instruction. A presentation system and age appropriate tables and chairs should be furnished for this area
- **Circulation** should be located adjacent to entry doors from the main corridor with visual control and access to workroom, TV Studio, and offices.
- **Leisure Reading Area** should accommodate lounge furniture to support collaboration and group work
- **Technology** to be wireless with ample power sources throughout the space. Provide space and infrastructure for two charging carts
- **Workroom** should be near the circulation desk; this room accommodates shelving for resources, tables and perimeter cabinets for equipment (laminator, poster maker, etc) and tables and chairs for group collaboration.



- **Storage Room** should have direct access to the main use room and should be equipped with 18 and 24-inch deep shelving, used primarily for equipment storage. Provide ample power sources for the charging of laptops carts
- **Television Studio** should be in close proximity to the Circulation Desk/Workroom/Office. No windows. It should be equipped for school wide broadcasting on a daily basis. Consideration should be given to the shape of the studio for broadcast desk, camera locations and lighting configurations with a green wall behind the location of the anchor desk.
- **Office** should be adjacent to circulation and have a window to allow for visual control of the main use area while sitting at the office desk. The office should be generous in space to allow the media specialist to work with staff, collaborate with teachers, and vendors, design lessons, and have conferences.

**DESIGN CONSIDERATIONS**

The Media Center should be located centrally on the ground floor for easy access from all learning areas, and away from noisy areas such as the cafeteria or multi-purpose room. There should be distinct internal “rooms” and no blind spots. The Media Center should be designed for multiple functions both during school hours and after. It would ideally have an exit onto a patio and be convenient to group restrooms for evening use by the public.

**PHYSICAL REQUIREMENTS**

Carpet, data outlets, phone/intercom, two instructional presentation spaces (primary storytelling and one large group instructional area

- Provide circulation desk with wide view of main floor and quick access to phone and main entrance with generous adjustable shelving behind desk. Desk to include lockable pencil drawers, lower cabinet drawers, counter top space for a printer, purposefully designed space for computers/book scanners, student self check out and a depressible mobile book drop with slit opening in the circulation desk.
- Provide simple square or rectangular room shape with no columns
- Placement of network jacks and sources of power is crucial in overall layout and flexibility of space.
- Careful placement of windows to complement bookshelf locations and heights
- Defined instructional areas wired for two Teaching Walls per detail in A/E Guide. Lighting to be independently switched for clarity of projections and darkening of different parts of the room
- Two computer network drops with adjacent quad power outlets near Computer Projection Systems
- Design to be sensitive to shapes and sound transmissions to avoid acoustical problems
- Floor boxes with data, and electric connections
- Intercom/Phone with adjustable volume

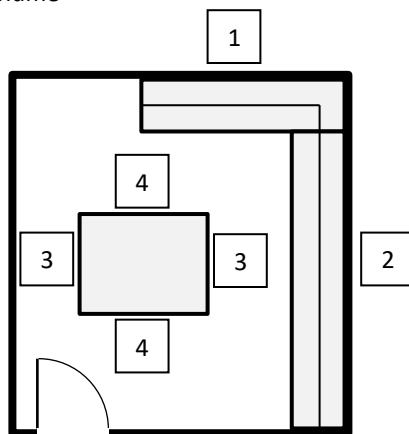

WORKROOM ELEVATIONS KEYPLAN – See Next Page

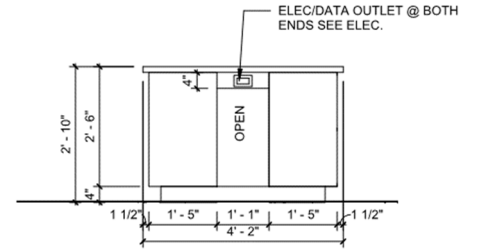
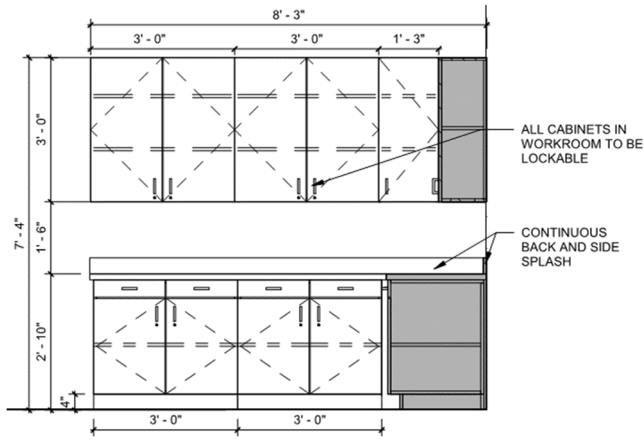

1 CASEWORK ELEVATION - MEDIA CENTER WORK RM

3 MEDIA CENTER WORK RM

1/4" = 1'-0"

1/4" = 1'-0"

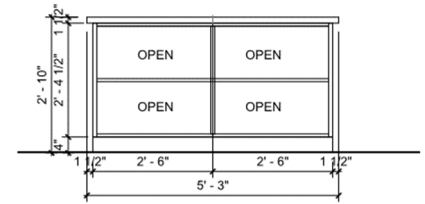
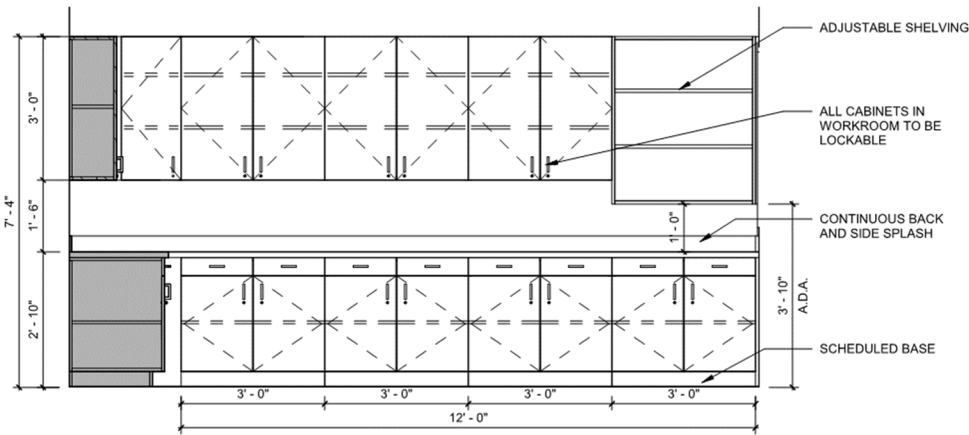

2 CASEWORK ELEVATION - MEDIA CENTER WORK RM

4 MEDIA CENTER WORK RM

1/4" = 1'-0"

1/4" = 1'-0"

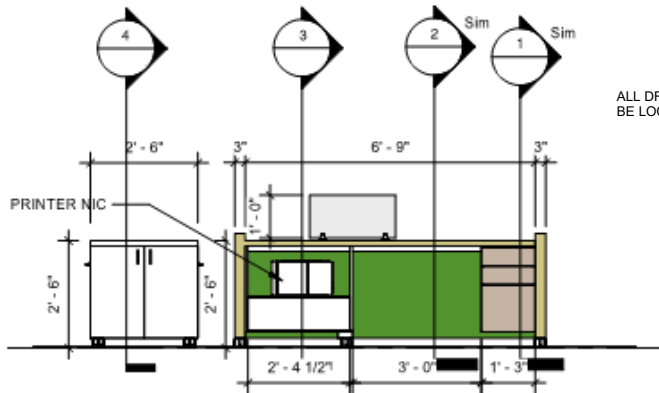

**A CASEWORK- MEDIA DESK- BACK**  
1/4" = 1'-0"

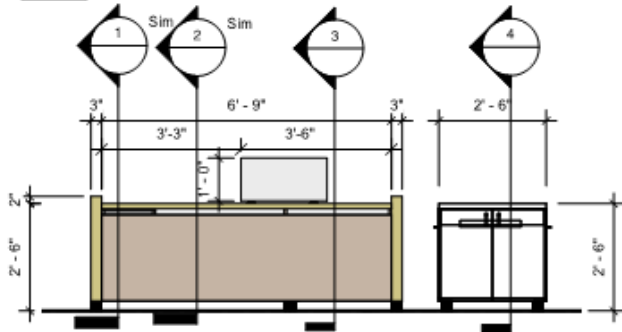

**B CASEWORK- MEDIA DESK- FRONT**  
1/4" = 1'-0"

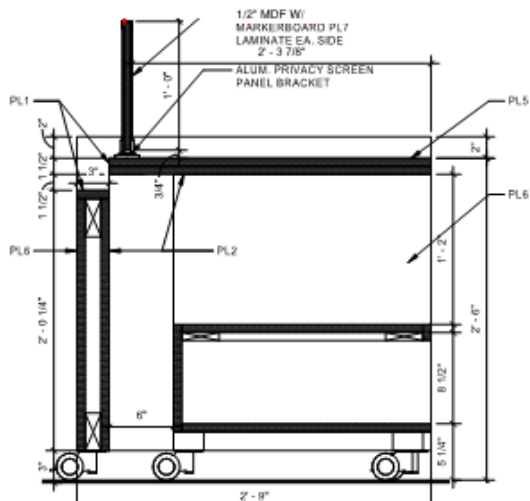

**3 INTERIOR CASEWORK SECTION- MEDIA DESK**  
3/4" = 1'-0"

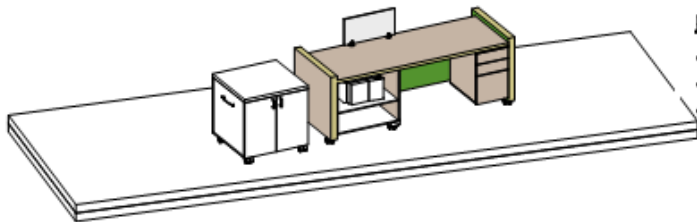

**5 MEDIA DESK BACK**

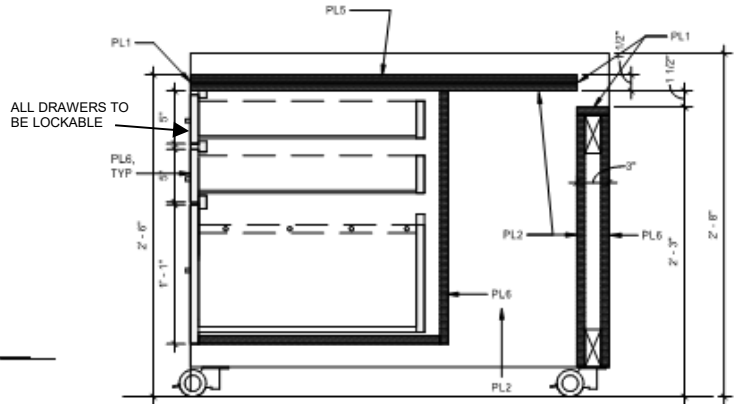

**1 CASEWORK - MEDIA DESK COUNTERTOP**  
3/4" = 1'-0"

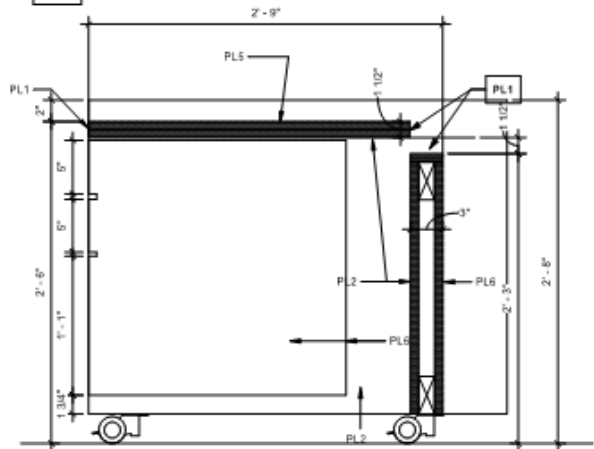

**2 CASEWORK - MEDIA DESK KNEE SPACE**  
3/4" = 1'-0"

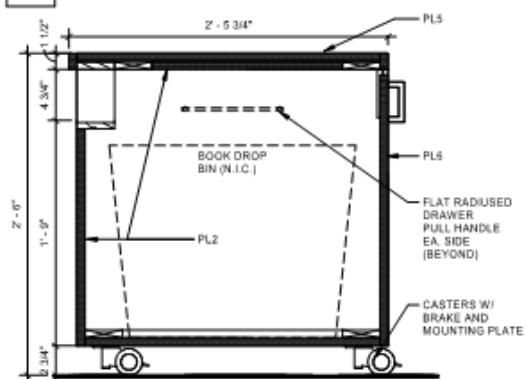

**4 INTERIOR CASEWORK SECTION- BOOK DROP**  
3/4" = 1'-0"

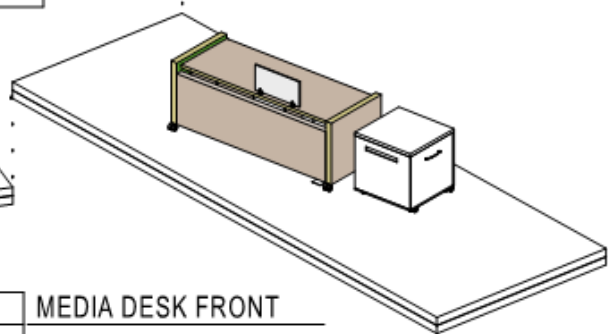

**6 MEDIA DESK FRONT**

# MAKERSPACE

## OBJECTIVES

To provide a flexible space for hands on learning, digital learning, CTE.

## ACTIVITIES

Team teachers engaged in conferencing, scheduling and planning strategies for students and conferences with parents.

## DESIGN CONSIDERATIONS

To be located adjacent to the third Large Group Instruction area of media center. Provide windows for observation by staff and other students.

## PHYSICAL REQUIREMENTS

### Architectural Criteria

- Provide base and wall cabinets along one wall with a sink. Cabinets to be open shelf and drawer units.
- Maximize the number of marker boards available in the space.
- Provide two 4'x4' tack boards.
- Provide 1" mini-blinds for windows

### Mechanical Criteria

- Provide individually controlled HVAC unit sized to accommodate students and equipment.
- Provide hot and cold running water to sink.

### Electrical Criteria

- Provide sixteen network drops with a minimum of two network drops available above base cabinets.
- Provide cabling in ceiling for classroom camera.
- Provide cabling in ceiling for wireless access point.
- Provide duplex outlets elsewhere around the space at 6' on center.
- Provide three electrical power reels mounted to the ceiling space evenly through the space.
- Provide intercom/phone with volume control and privacy feature.

### Furniture, Fixtures and Equipment

- Provide work tables that are easily moved and adjusted.
- Provide flexible seating options.

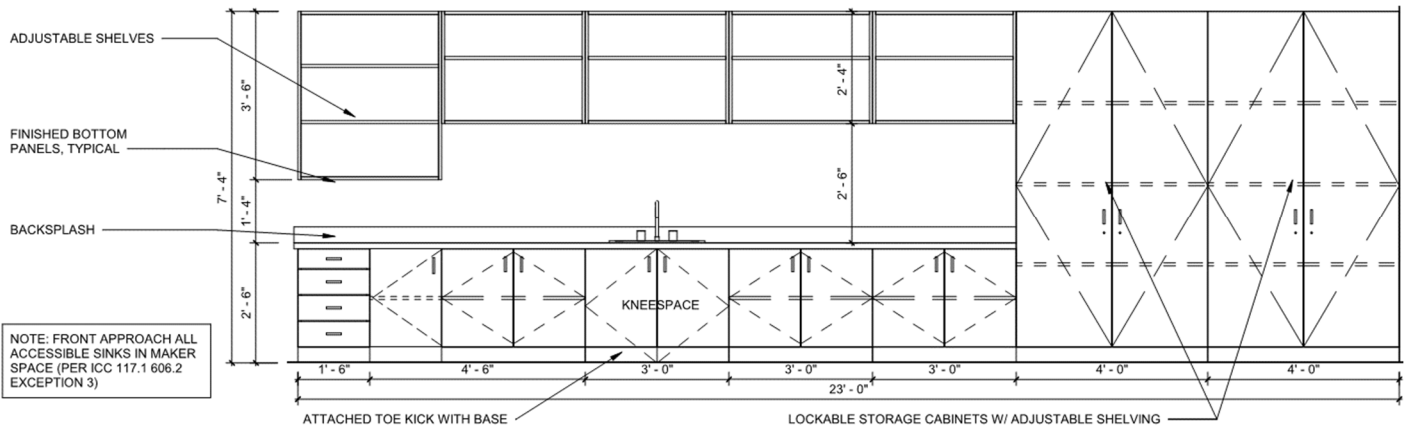
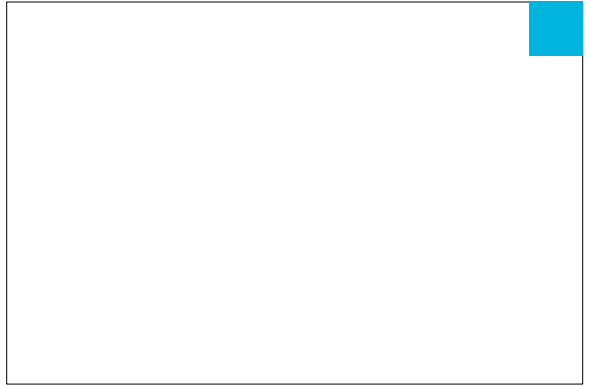

CASEWORK ELEVATION - MAKER SPACE

1/4" = 1'-0"

## **MULTIPURPOSE ROOM**

### **OBJECTIVES**

The goal of the CMS Physical Education program is to instill positive attitudes and behaviors for a lifetime commitment to joyful physical activity and good health. Physical Education is a sequential instructional program that provides learning experiences that develop physical and mental fitness, motor skills and moral social behavior. It is based on the study of human movement and includes educational games/sports, dance, and gymnastics with fitness concepts integrated into all of the content areas. A variety of teaching styles is used to develop experiences that encourage students to become efficient, versatile, and creative movers.



All Charlotte-Mecklenburg students will be able to:

- Develop an acceptable level of health-related fitness and demonstrate knowledge, skill, and behaviors to promote personal fitness;
- Acquire motor skills necessary for successful participation in lifetime physical activities of personal choice; and
- Understand and value lifetime participation in physical activity.

### **CAPACITY**

1 teacher

### **PHYSICAL REQUIREMENTS**

- The multi-purpose room should be located adjacent to the dining area and separated by folding partition for PE activities
- The platform should be located directly across from the folding partition and must be wheelchair accessible
- Provide acoustical treatment of walls and ceiling in multi-purpose room to accommodate PE activities
- Provide large and tall storage space for equipment
- Provide intercom/phone with volume control and privacy feature.
- Provide vinyl composition tile floor - marked with one rectangle around court and mid-line for two cross courts. A broken line divides the rectangle lengthwise and divides the width of each half court. One 8'x8' four square in each corner of the rectangle, one large circle in each half of multi-purpose room.
- Provide two adjustable basketball goals
- Provide protected clock
- Provide duplex electric outlets on each wall, at least two dual outlets on each wall
- Provide sound system with outlets for a microphone at platform (at multipurpose room)
- Multi-purpose room should have minimum 2 data outlets each paired with quad outlets
- Provide motorized 10' x 10' projection screen over platform and electrical connections.
- Platform should be equipped with main traveler, valance, and side/rear cycloramas.
- Platform should be equipped with front stage light bar and side stage dimmer controls which are accessible from the platform
- Provide one data outlet on platform paired with quad outlet
- Provide one data outlet at base of platform paired with quad outlet
- Provide one large storage room accessed from the multipurpose room for PE equipment and as a teacher office. This room should have double wide doors so that gymnastics equipment, mat, and other equipment can be easily moved in and out. This same room should be equipped with shelves 18" deep for balls, bats, nets, golf clubs, and paddles. Ball shelves should tilt toward back to prevent balls from rolling off shelves. Need lip on the front of shelves. Wall brackets are needed to hang tennis rackets and badminton rackets flat. Wall hooks are needed for jump ropes. Also provide space for a teacher's desk and chair, with power and data at desk.
- Provide separate specific area for chair storage, (500 – 600 chairs)

- Install electrical outlets on each wall of storage room
- Provide separate security system for multi-purpose room
- Provide separate intercoms to platform, multi-purpose, and dining
- Refer to A/E Guide Section 11.2 for requirements of climbing wall mounting in MultiPurpose Room
- Any windows in this space should be at least 10' above the finished floor.
- Ceiling to be 20' AFF minimum to accommodate basketball games

## **RECEPTION / SECRETARY'S AREA**

### **OBJECTIVES:**

To provide a reception area that is warm, inviting and projects a professional image. The reception area should efficiently accommodate secretarial staff, students, visitors, and parents.

### **CAPACITY**

8-10 people/visitors and 2 administrators, with 2 work stations behind counter.

### **ACTIVITIES:**

- Monitoring of main entry camera and control of entry door locks.
- Greeting of parents and visitors.
- Control point of administrative suite.
- Registration of students entering or leaving during school hours.
- Broadcast of announcements.
- General secretarial activities and duties.

### **DESIGN CONSIDERATIONS**

- Must have visual control over front entry of school and main corridor. Ideally have visual control over front parking areas.
- Proximity to principal and/or assistant principal.
- Adjacent to health room.
- Access to workroom and storage rooms.

### **PHYSICAL REQUIREMENTS:**

#### Architectural Criteria

- Provide lobby/waiting area with functional seating arrangement.
- Provide desk height reception counter to divide waiting from secretarial spaces- Camera/front door locking security system to be integrated.
- Provide space for 2 work stations behind counter.
- Front door vestibule to provide security with locked doors to direct circulation through main office area.
- Visual access should be provided to front entrance to school and to the area outside the front entrance.
- Provide carpeted floors and/or VCT on the public side of the reception counter.
- Provide visual and audible access to Health room.
- Provide built-in coat closet.
- Provide 1" mini-blinds for all windows typical.

#### Mechanical Criteria

#### Electrical Criteria

- Provide six data outlets, each paired with a duplex electrical outlet, located on opposite walls and in reception counter to facilitate alternate furniture arrangements
- Provide duplex outlets elsewhere around the space at 6' on center
- Provide cabling in ceiling for wireless access point.
- Provide space for master intercom console and appropriate electric and communications connections.
- Provide space for master telephone and fax console.

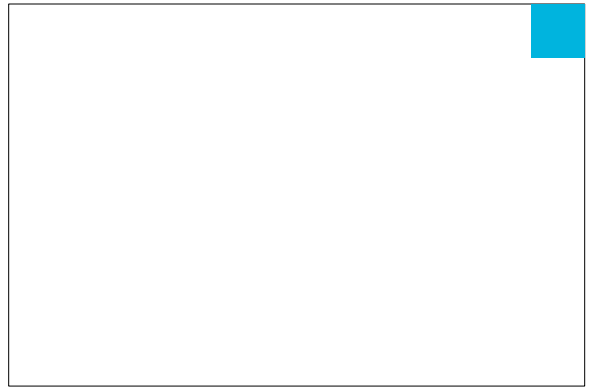

- Provide intercom/phone with volume control and privacy feature.
- Provide monitor mounted above head height facing secretarial staff. Provide cable TV connections and proximity to electricity with structural wall blocking for mounting monitor.
- Fire alarm and Intercom head end located in this area

#### Furniture, Fixtures and Equipment

- Provide reception counter with a combination of lockable storage units and open space to house three-drawer file cabinets below.
- Provide built-in display case.
- Provide two 4'x6' tackboards.



## **PRINCIPAL'S OFFICE**

### **OBJECTIVES**

The school administrative offices should provide a space wherein school-related business and concerns can be addressed with dignity in an attractive and suitable environment.

### **CAPACITY**

2-6 people/guests - executive desk suite of furniture and conference table and chairs with credenza and bookshelves typical

### **DESIGN CONSIDERATIONS**

- Office should be near but not adjacent to the main reception area
- Office should be in close proximity to administration team, student records and guidance area
- Office should be adjacent to dedicated conference room
- Administration suite should be designed so that the Principal's office can be located on either end of the suite of offices. Two options for locations, adjacent to a conference room is preferable
- Conference room to be equipped with marker board, tack board and bookshelves, typical

### **PHYSICAL REQUIREMENTS**

- Provide carpeted floor
- Provide two computer outlets, each paired with a quad electrical outlet, located on opposite walls to facilitate alternate furniture arrangements
- Provide duplex outlets elsewhere around the space at approximately 6' on center
- Provide Intercom/phone with volume control and privacy switch
- Provide 1" mini-blinds for windows typical

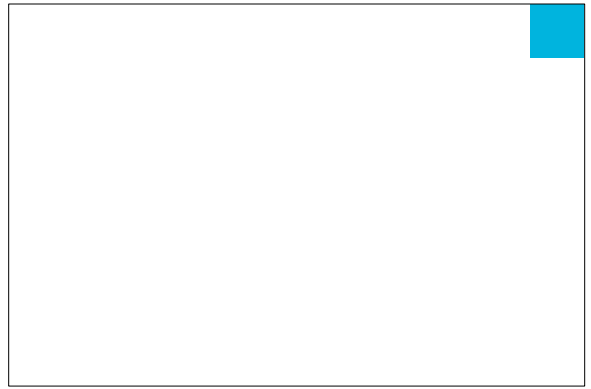

## **ASSISTANT PRINCIPAL'S OFFICE**

### **OBJECTIVES**

The Assistant Principal's office should provide a setting where daily school business, as assigned, can be transacted.

### **CAPACITY**

2-4 people/guests. Assist. Principal executive desk suite of furniture

### **DESIGN CONSIDERATIONS**

Close to principal's office, main reception/entrance and conference room

### **PHYSICAL REQUIREMENTS**

- Provide carpeted floor
- Provide receiving area separate from the main office reception area
- Provide access to secondary exit from administration area
- Provide two computer outlets, each paired with a duplex electrical outlet, located on opposite walls to facilitate alternate furniture arrangements
- Provide duplex outlets elsewhere around the space at 6' on center
- Provide phone/Intercom with volume control and privacy switch
- Provide 1" mini-blinds for windows

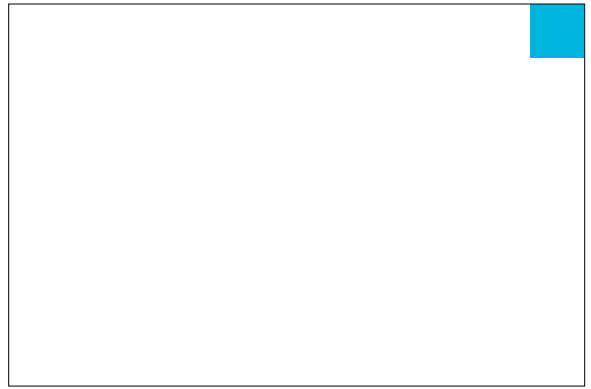

# **FINANCIAL SECRETARY OFFICE**

## **OBJECTIVES**

Financial Secretary/Bookkeeping office should provide a quiet and private setting where school business transactions can be accommodated.

## **CAPACITY**

2-4 people

## **DESIGN CONSIDERATIONS**

Locate in administration office complex but away from high traffic areas.

## **PHYSICAL REQUIREMENTS**

- Provide carpeted floor
- Provide two data outlets paired with quad electrical outlets
- Provide duplex outlets elsewhere around the space at 6' on center
- Provide intercom/phone with volume control and privacy switch

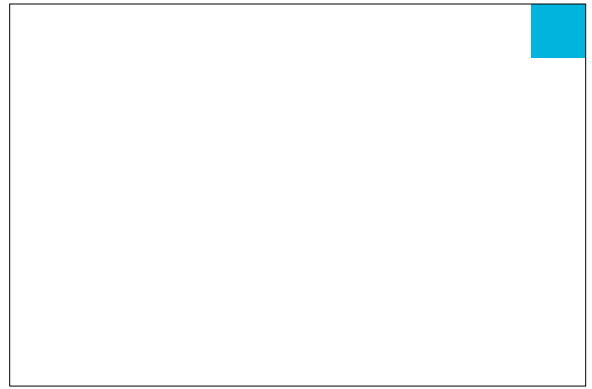

## **ITINERANT STAFF WORK SPACE**

### **OBJECTIVES**

To provide a "home base" for itinerant staff and allow for interaction and planning between professionals

### **CAPACITY**

Four to six persons

### **ACTIVITIES**

- Teacher and Staff Planning
- Office /Conference Space
- Storage of itinerant materials

### **DESIGN CONSIDERATIONS**

- Locate itinerant staff in close proximity to main entrance, administration area and guidance area
- Locate to allow immediate access to a conference room
- Locate in close proximity to adult restrooms

### **PHYSICAL REQUIREMENTS**

- Provide carpeted floor
- Provide intercom/phone with volume control and privacy switch
- Provide six computer outlets, each paired with a quad electrical outlet, minimum of one on each wall
- Provide duplex receptacles elsewhere around the perimeter of the space at 6' on center
- Provide 4'X 8' tack board
- Provide 1" mini-blinds for windows
- Workstations to be "touch-down" size, i.e. 6' x 6'

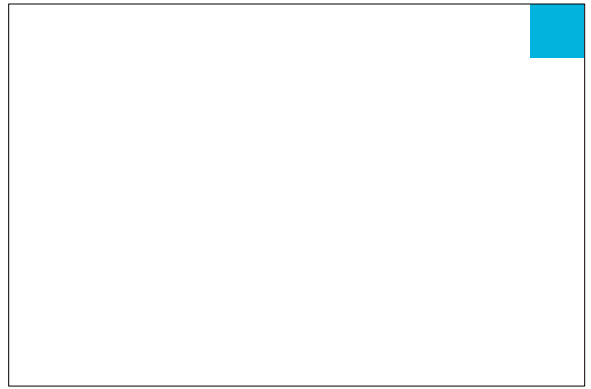

# **CONFERENCE ROOM**

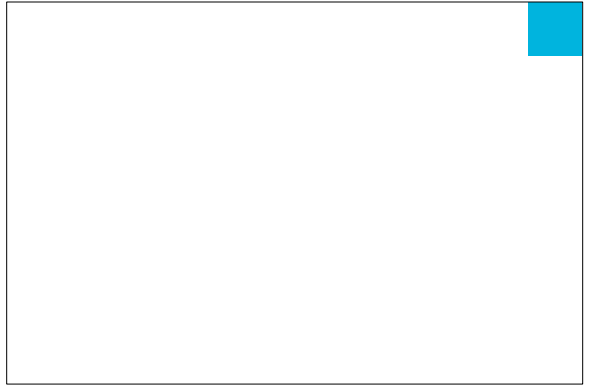

## **OBJECTIVES**

The Conference Room should be shared by all administration personnel and should provide a quiet inviting setting for conferences and group assemblies for student or school business.

## **CAPACITY**

10-12 people

## **ACTIVITIES**

- Parent conferences
- Testing evaluations

## **DESIGN CONSIDERATIONS**

Adjacent to Principal's office, Assistant Principal Offices and reception area – If possible twin locations of office/conference suites are to be provided to offer maximum flexibility to staff. This can be provided by designing two ends of a main administration wing with an office-conference room pairing.

## **PHYSICAL REQUIREMENTS**

- Provide one data outlet paired with a duplex electrical outlet
- Provide duplex outlets elsewhere around the space a 6' on center
- Provide television connection, and mounts for monitor
- Provide marker board and tack board
- Provide intercom with volume control and privacy switch
- Provide carpeted floor

# **WORKROOM**

## **OBJECTIVES**

To provide workspace for teachers, secretaries, principal and assistant principals.

## **CAPACITY**

2-4 people

## **ACTIVITIES:**

- Storage (school supplies and system forms).
- Copying of materials.
- Laminating, assembling and distribution of staff mail
- General clerical tasks.

## **DESIGN CONSIDERATIONS**

Locate in principal’s office suite close to secretarial area and on a major corridor.

## **PHYSICAL REQUIREMENTS**

### Architectural Criteria

- Provide vinyl tile floor.

### Mechanical Criteria

### Electrical Criteria

- Provide intercom/phone with volume control and privacy feature.
- Provide two computer outlets in the workroom and one in the storage room, each adjacent to a quadruplex electrical outlet.
- Provide electrical outlets elsewhere at 6’ on center.

### Furniture, Fixtures and Equipment

- Provide one wall of built-in base and overhead cabinets. All cabinets to be lockable. Units to be a mix of closed, open shelves, and drawers.
- Provide 12” deep shelving on all available walls of storage room.
- Provide work table per the details included in the A/E Guide Appendix.
- Provide teacher mail slots per the details included in the A/E Guide Appendix.

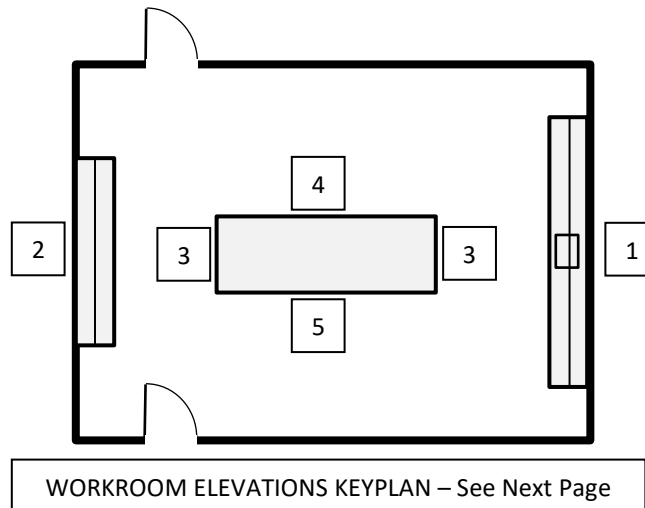

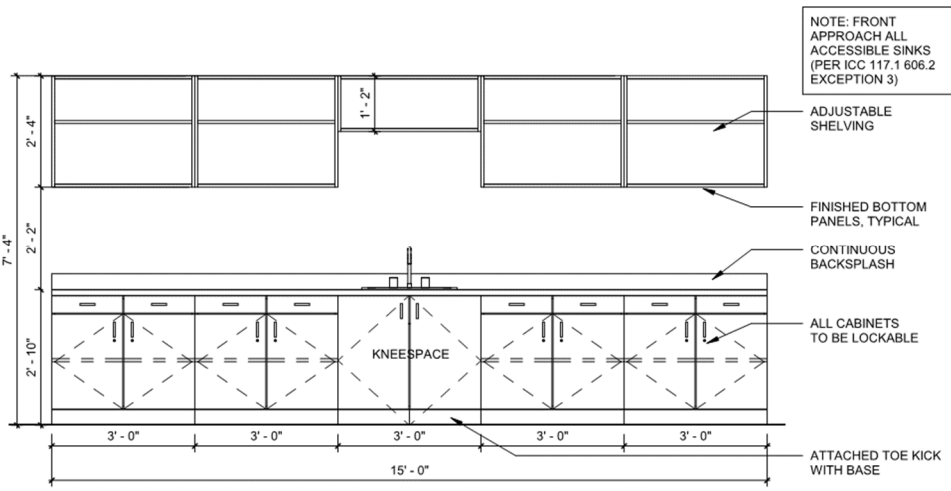

**1 CASEWORK ELEVATION - WORKROOM**

1/4" = 1'-0"

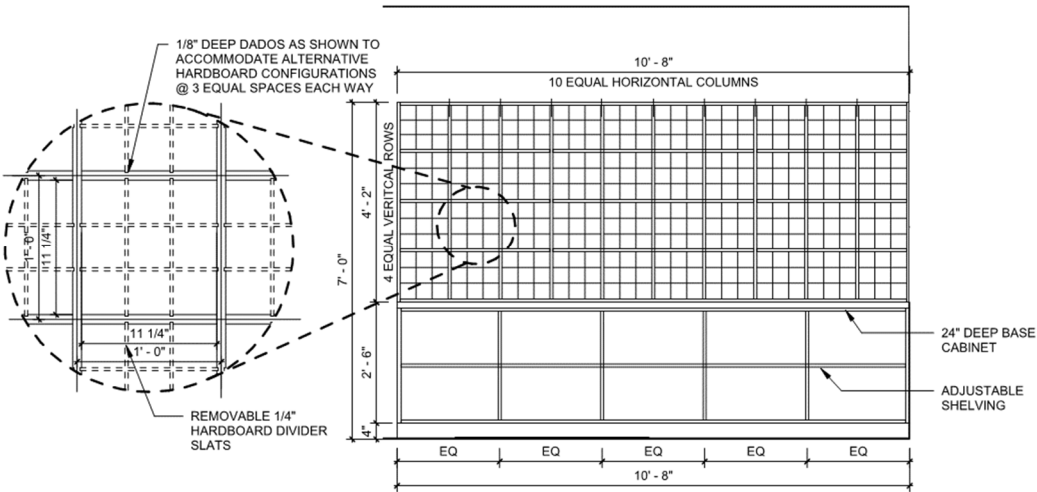

**2 MAILBOX CASEWORK**

1/4" = 1'-0"

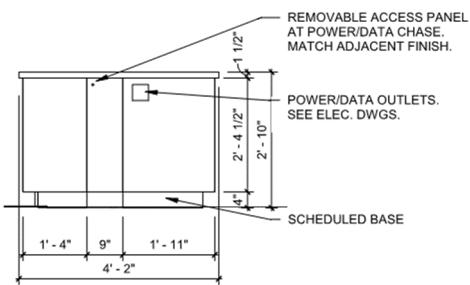

**3 CASEWORK- WORKROOM**

1/4" = 1'-0"

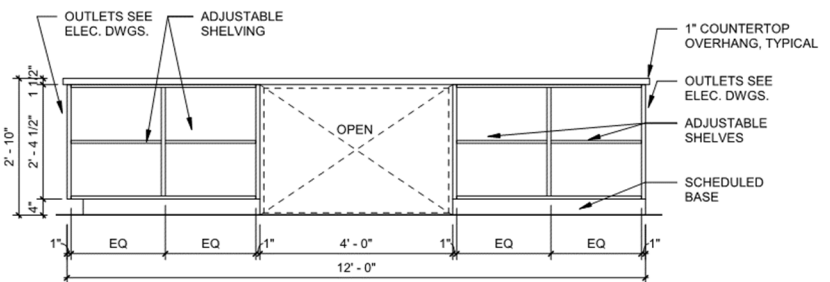

**4 CASEWORK- WORKROOM**

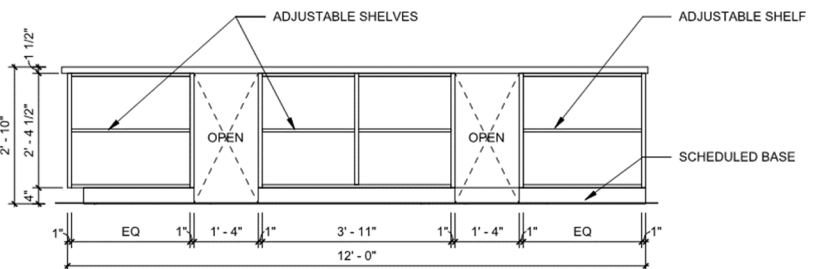

**5 CASEWORK- WORKROOM**

1/4" = 1'-0"

# **FACULTY BREAKROOM**

## **OBJECTIVES**

To provide space for teachers and staff to take breaks and eat lunch.

## **CAPACITY**

6-8 people

## **ACTIVITIES:**

- Take breaks.
- Prepare coffee.
- Store and eat lunches.
- Access vending machines.

## **DESIGN CONSIDERATIONS**

Locate in proximity to classroom wing. Provide space for (4) vending machines, a refrigerator, and base and wall cabinets where a microwave could be placed.

## **PHYSICAL REQUIREMENTS**

### Architectural Criteria

- Provide vinyl tile floor.

### Mechanical Criteria

- Provide sink with hot and cold water.

### Electrical Criteria

- Provide intercom/phone with volume control and privacy feature.
- Provide electrical outlets at 6' on center.

### Furniture, Fixtures and Equipment

- Provide one wall of built-in base, sink and overhead cabinets. Units to be a mix of closed, open shelves, and drawers.

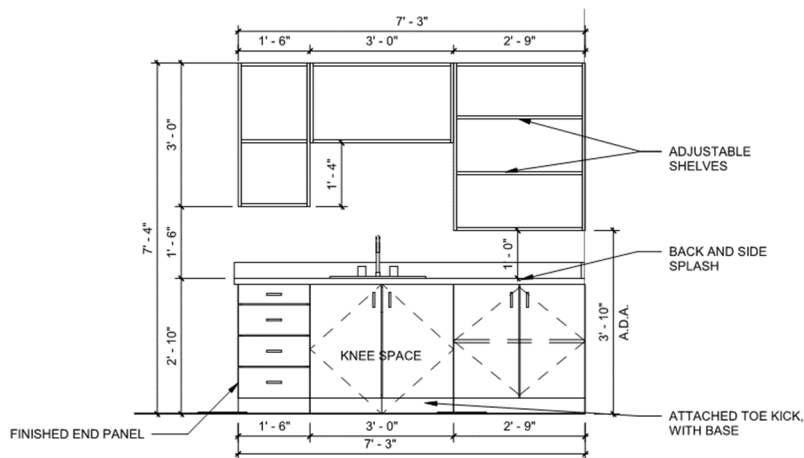

**CASEWORK ELEVATION - FACULTY BREAK**

1/4" = 1'-0"



# **STUDENT RECORDS**

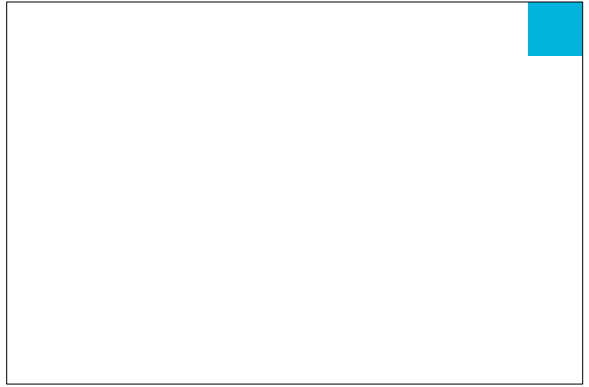

## **OBJECTIVES**

To provide secure fire resistant area for storage of student records and school financial records.

## **CAPACITY**

1-2 people

## **ACTIVITIES**

- Storage of student files
- Retrieval of information
- Logging of information onto computer system

## **DESIGN CONSIDERATIONS**

Locate adjacent to Student Services Office (for Registrar access) and adjacent to Financial Secretary Office. Locate in proximity to Principal and Assistant Principals.

## **PHYSICAL REQUIREMENTS**

- Provide intercom/phone with volume control and privacy switch
- Provide one data outlet paired with a duplex electrical outlet
- Provide duplex outlets elsewhere around the space at 6' on center
- Provide minimum of 1-hr. enclosure
- Provide carpeted floor
- HVAC should be provided for occupiable office

# **HEALTH ROOM**

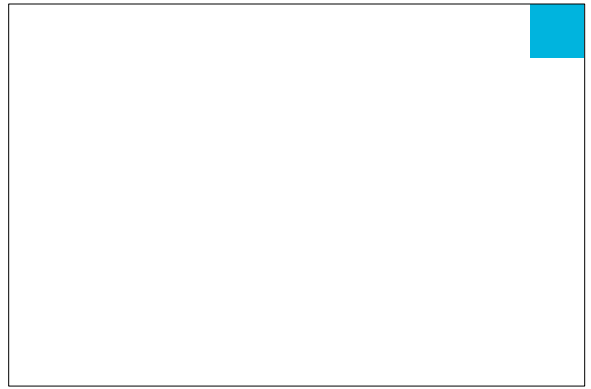

## **OBJECTIVES**

To provide adequate space for school nurse to assess needs of students and staff in a private, confidential area; to triage sick and/or injured students, administer first aid and monitor status while waiting for parent pick-up; conduct required screenings and evaluations; to provide health counseling, case management and communicate with health care providers; and, serve as a center for health and wellness resources, education and activities for staff and students.

## **CAPACITY**

4-6 people

## **ACTIVITIES**

- Student examinations and/or treatment by the school nurse
- Resting area for sick and injured students or waiting for parent pick-up
- Administration of medication(s) and treatments
- Storage (first aid supplies, medication, linens for beds, wheelchair, scale, health information resources)
- Conduct required screenings and evaluations
- Nurse/student confidential conferences
- Confidential conversations with parent, staff and/or healthcare providers
- Collaboration with staff on health and wellness activities

## **PHYSICAL REQUIREMENTS**

- Located near the main office, but away from the public, entrance behind the secretary/receptionist for supervision on days nurse is not present or occupied outside the health room
- Provide window for observing students from secretary area, but placed for privacy/confidentiality so visitors entering the reception area cannot see students in the health office
- Ideally two entrances; one to office area and one to hallway
- Provide 1" mini-blinds for windows for privacy
- Provide vinyl composition tile floor or rolled rubber heat welded (no carpet)
- Provide private accessible restroom with hot (tempered)/cold water and accessible shower (if a shower is not otherwise provided within the school at a modified rest room) with floor drain typical.
- Provide sink with hot (tempered) and cold water and counter with lockable drawers and storage
- Provide paper towel and liquid soap dispensers at the sink
- Restroom should be sized to allow for a changing area and the use of a small cot
- Provide intercom/phone with volume control and privacy switch
- Provide two computer outlets, each paired with quadruplex electrical outlet, located on opposite walls to facilitate alternate furniture arrangements
- Provide duplex outlets elsewhere as needed
- Provide wall clock
- Provide privacy curtain from the ceiling to visually separate cots
- Provide ADA-compliant mini refrigerator with lock (include in GC contract), positioned within base cabinet.

## **EQUIPMENT**

- Provide 2 cots in storage near restroom
- Provide four drawer lockable file cabinet for confidential files



## **STUDENT SERVICES OFFICE & CONF. RM.**

### **OBJECTIVES**

The Guidance and Student Services program is designed to assist students and their families with students' normal progression through the developmental stages in the areas of learning, social skills, and career planning. Each elementary school has a full-time Student Services Specialist (certified in school psychology with training school counseling and school social work). To deliver a comprehensive Student Services program, the Student Services Specialist:

Provides classroom guidance concerning personal and social skills, career development and study skills  
Consults with school staff and parents  
Conducts psychological evaluations of students who have learning or behavioral problems  
Provides individual and group counseling  
Serves as liaison between home, school and community resources

### **CAPACITY**

Office            3-5 people with corner area for “kid-friendly” interviews

Conference      6-10 people

### **DESIGN CONSIDERATIONS**

The Student Services office should be located near the mainstream of student traffic, with direct student entrance without going through the administrative offices. Access to the administrative office for records is desirable. Separation from high noise areas is needed.

### **PHYSICAL REQUIREMENTS**

#### Office:

- Provide two data outlets, each paired with quad electrical outlet, located on opposite walls to facilitate alternate furniture arrangements
- Provide duplex outlets elsewhere around the space at 6' on center
- Provide intercom/phone with volume control and privacy feature.
- Provide carpeted floors
- Kid-friendly interview space

#### Conference

- Provide intercom/phone with volume control and privacy feature
- Provide data connection
- Provide television connection for wall mounted monitor

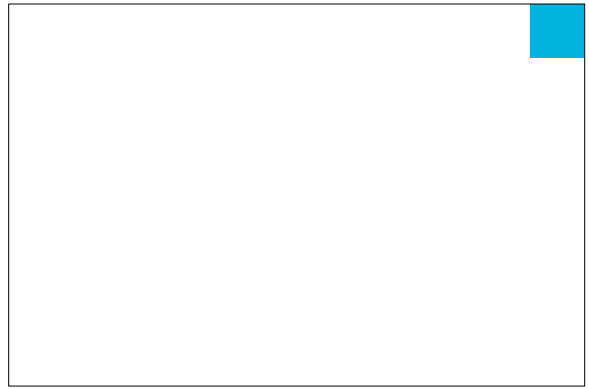

# PARENT CENTER

## OBJECTIVES

The Parent Center is a place for interaction between parents, teachers and administrators. It is also the location for parent resources and educational information.

## CAPACITY

6-8 people

## DESIGN CONSIDERATIONS

Parent center should be located close to administration area, main entrance, and staff accessible restrooms. Must be wheelchair accessible.

## PHYSICAL REQUIREMENTS

### Architectural Criteria

- Provide carpet.

### Mechanical Criteria

### Electrical Criteria

- Provide three data outlets, each grouped with a quadruplex receptacle. Provide wireless access point.
- Provide duplex outlets elsewhere around the space at 6' on center.
- Provide intercom/phone with volume control and privacy feature.

### Furniture, Fixtures and Equipment

- Provide three 48"x84" high book shelf units.
- Provide 6' long counter with sink and under counter storage consisting of drawer and closed lockable units.
- Provide one 4'x8' tackboard.

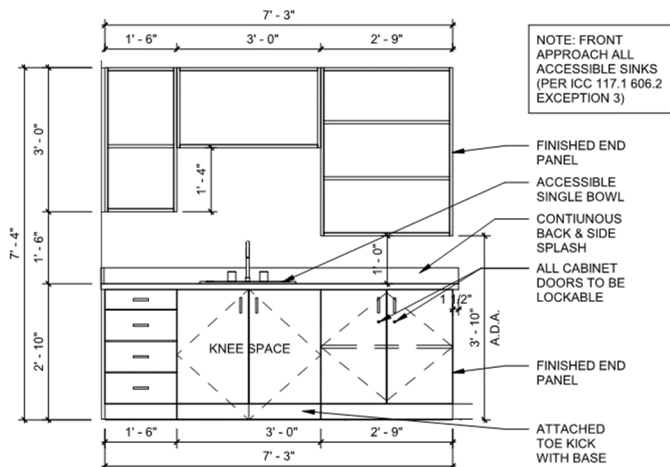

CASEWORK ELEVATION - PARENT CNTR

$1/4" = 1'-0"$

# WELLNESS ROOM – ELEMENTARY SCHOOL

## OBJECTIVES

Employee wellness rooms can help ease stress and tension around the workplace. Per Section 4207 of the Patient Protection and Affordable Care Act, new mothers also need a private, designated space to nurse. This space is intended for staff use only.

## CAPACITY

1-2 people

## ACTIVITIES:

- Accommodate nursing mothers.
- Provide a private area for administering medication, stress relief, or work breaks.
- Provide an area for employees with migraines to receive sensory relief.

## DESIGN CONSIDERATIONS

- The Wellness Room is to accommodate casework for storage, sink and small refrigerator, as a private room for individual use.

## PHYSICAL REQUIREMENTS

### Architectural Criteria

- Provide a design scheme with subtle colors, pale hues like light gray and beige, to make it easier for employees to relax and unwind.
- Provide carpeted floor.
- Provide high-NRC acoustical ceilings.
- Provide entry lock door hardware with occupied/vacant indicator.
- Provide casework with sink and under-counter refrigerator.
- Provide ADA-compliant mini refrigerator with lock (include in GC contract), positioned within base cabinet.

### Mechanical Criteria

- Provide a small sink at the casework with hot (tempered) and cold water.
- Provide heating/cooling with individual sensors to control space temperature.

### Electrical Criteria

- Provide LED lighting with the ability to dim lights.
- Provide intercom/phone with volume control and privacy feature.
- Provide power for refrigerator.

### Furniture, Fixtures and Equipment

- Provide comfortable furniture for employees to rest in, with enough flat surfaces to place their belongings.

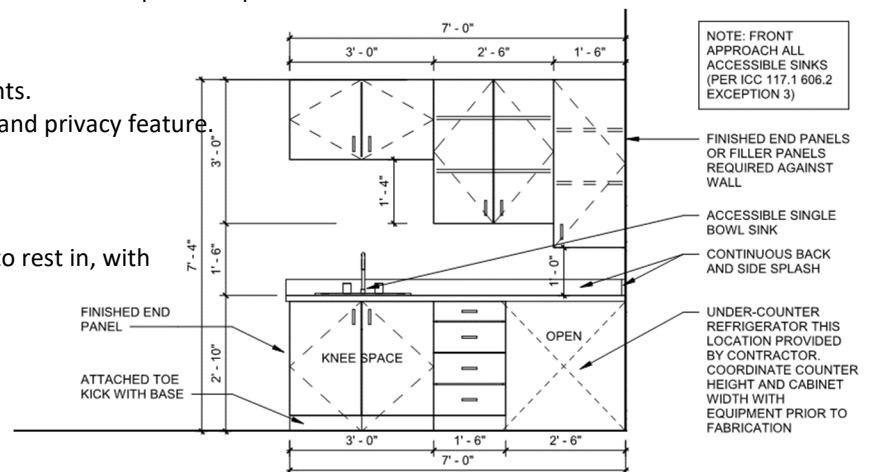

## CASEWORK - WELLNESS

1/4" = 1'-0"

## **SRO OFFICE**

### **OBJECTIVES**

To provide a space for a police officer assigned to the school.

### **CAPACITY**

1 resource officer

### **DESIGN CONSIDERATIONS**

Should be located in the administration area of the school, preferably close to the main or secondary entrance to the administrative area.

### **PHYSICAL REQUIREMENTS**

#### Architectural Criteria

- Provide vinyl tile if accessed from Corridor. Provide carpet if accessed from Admin.

#### Mechanical Criteria

#### Electrical Criteria

- Provide two computer outlets, each adjacent to a quadruplex electrical outlet.
- Provide duplex electrical outlets elsewhere at 6' on center.
- Provide intercom/phone with volume control and privacy feature.

#### Furniture, Fixtures and Equipment

- Provide one 4'x6' tackboard.

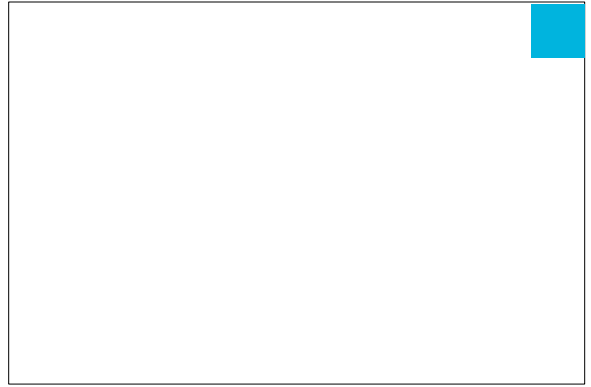

# **CAFETERIA AND KITCHEN**

## **OBJECTIVES**

Nutrition programs play a vital role in the education of students. As a “partner in education” it is the role of child nutrition programs to make mealtime a pleasant experience by providing adequate dining and food preparation facilities which will encourage students to consume the nutritious meals needed for growth, development, and learning readiness. The dining area is sized for three seatings of the design student population.



## **CAPACITY**

Student Population/Three Seatings

## **ACTIVITIES**

Receiving food and associate kitchen materials and equipment in order to prepare food for student’s meals to include breakfast, lunch and occasional snacks and community events.

## **DESIGN CONSIDERATIONS**

- Dining area: Located adjacent to the multi-purpose room with a movable partition to divide these two spaces acoustically insulated to minimize noise from the adjacent area.
- Serving area: Adjacent to kitchen and dining with easy access for supply or fresh food; accessible with appropriate counter heights.
- Food preparation: The food preparation and storage areas shall be accessible from a loading area to allow for deliveries of supplies and the removal of food debris.
- Dish wash area: Adjacent to dining room with traffic pattern not to interfere with serving lines.
- Manager’s office: Locate at rear of kitchen with full view of back door, storage entrances, and preparation areas. Window to outside with security screen.
- Employee restroom: Located adjacent to food preparation area opens to locker room.
- Locker room opens to kitchen with 10-12 double height lockers and associated closet for data
- Storage area: The food preparation and storage areas shall be accessible from a loading area to allow for deliveries of supplies and the removal of food debris. If storage is located directly next to a cooler or freezer, additional insulation is required to prevent possibility of mold.
- Separate security system for kitchen is recommended to allow early access by staff. Area to accommodate separate key pad zone
- Provide buzzer/doorbell at back entrance. Buzzer to “announce” in Kitchen near manager’s office
- Provide peephole on back door.
- Provide can wash facility with mop rack in delivery area and accessibility to dumpsters

## **PHYSICAL REQUIREMENTS**

Dining Area:

- Provide 20 foot candles minimum. Dual switch to 40 foot candles of light is recommended for special occasions
- Provide additional wiring in walls for future satellite serving areas
- Provide 2 Ethernet ports and 2 electrical outlets over entrances to serving area for flat screen. See A&E Guide for current minimum requirements, typical.
- Provide ample electrical outlets
- Provide VCT Flooring
- Provide intercom
- Provide television connection – minimum of two at 18” AFF



- Provide minimum two computer network drops with adjacent quad power outlets
- Do not limit all dining to the inside of the building. Patios and outdoor gardens may be utilized for dining
- Plan windows that are at eye level and allow light to enter and provide a pleasant outside view
- Material selections for ceilings and walls should be as sound absorptive as possible to reduce noise. Flags and ceiling hangings can reduce noise levels
- Provide electric water cooler with bottle filler in Dining Area. Locate water cooler adjacent to Serving line.

#### Serving Area:

- 70 foot candles of light is recommended
- Electrical connections required for equipment
- Floor drains as required for equipment
- Data outlet paired with quadruplex outlet at each cashier
- Provide VCT floor
- Smooth durable washable wall surfaces

#### Food Preparation:

- 70 foot candles of light is recommended. Provide natural light whenever possible
- Provide quarry tile or epoxy floor
- Provide electrical wiring as required for all equipment.
- Floor drains or floor sinks to be provided as required for equipment
- Provide vertical closure panels over the top of all walk-in freezers and coolers. Locate floor drains for these coolers and freezers out of traffic path.
- Provide hand wash sinks, where required server, kiosk and kitchen locations. Provide soap and tri-fold paper towel dispensers at all hand wash sink locations.
- Kitchen hood area: The exhaust hood shall be stainless steel with adequate lighting. The water source under the hood shall have a vacuum breaker. The fire suppression system push-button activator shall be located near the entry/exit door. Include stainless steel utility chase and fire suppression system.
- The utilities for the equipment shall be arranged in such a way to facilitate easy cleaning behind the equipment.
- Drains are needed throughout, especially under the braising pan, icemaker, etc.
- The location of drains should be out of circulation paths and appropriate for use when the equipment is tilted and the water is draining, and so that steam from the drain does not interfere with operation (pilot lights, etc.) of other equipment.
- CO sensor with digital readout required in kitchen.
- Provide stand-alone HVAC system

#### Dish Wash Area:

- 70 foot candles are recommended
- Provide direct wiring of dish machine
- Provide hood with fan to draw steam out of area
- Provide water temperature 140 degrees to kitchen 180 degrees by booster heater on demand
- Provide garbage disposal
- Provide smooth durable washable wall surfaces
- Hose bibb shall be located in the dish room.
- Provide wall mounted fans in the dishwashing room and as directed by CMS.

#### Storage Area:

- 70 foot candles are recommended
- Dry storage area to be ventilated with fresh air venting system
- A notice board for menu, message, and other types of communication is essential
- Must have flexible shelving. When planning new storage rooms think in terms of rows of shelving with adequate aisles between.
- Provide 4' x 6' bulletin board for employee communication.
- Rows of shelving with adequate aisles between are desired.
- Provide quarry tile floor
- Provide smooth durable washable wall surfaces

Manager's Office:

- 70 foot candles are recommended
- Provide ample electric outlets
- Provide 3'x 4' bulletin board.
- Provide smooth durable washable walls
- Provide 2 Data outlets paired with quadruplex outlets
- Provide intercom/phone with volume control and privacy feature.
- Provide telephone connection with kitchen speaker-bell

Internal cold storage freezer and cooler

Provide all kitchen food preparation equipment as specified by A&E Guidelines.

Provide 1" mini-blinds for windows, typical

Provide recycling area with bins in kitchen, delivery area, and cafeteria dining area

## **PLANT OPERATIONS**

### **OBJECTIVES**

To provide space for the activities involved with Plant Operations and Maintenance on a day to day basis

### **DESIGN CONSIDERATIONS**

- Custodial/storage rooms should be located near opposite ends of the floor plan to provide convenient distances to all classrooms and storage areas as well as trash pick-up and recycling areas.
- Laundry should be located near one of the custodial rooms
- Loading area should be located adjacent to the kitchen-cafeteria area
- Storage room located near loading dock for central receiving and staging

### **PHYSICAL REQUIREMENTS**

- Each custodial/storage room should contain a mop sink, mop rack, and shelving
- Outdoor storage will be provided by owner, post occupancy and should be added to the site plan for location of circulation and security. Outdoor storage should be oriented towards the play fields. Provide concrete pad and appropriate driveway and sidewalk access and/or ramp to future storage container



## **CUSTODIAL ROOMS**

### **OBJECTIVES**

To provide space for the storage of supplies and equipment used on a day to day basis

### **DESIGN CONSIDERATIONS**

- Custodial/storage rooms should be located near opposite ends of the floor plan to provide convenient distances to all classrooms and storage areas as well as trash pick-up and recycling areas.
- Laundry should be located near one of the custodial rooms
- Loading area should be located adjacent to the kitchen-cafeteria area
- Storage room located near loading dock for central receiving and staging



### **PHYSICAL REQUIREMENTS**

- Each custodial/storage room should contain a mop sink, mop rack, and shelving
- Outdoor storage will be provided by owner, post occupancy and should be added to the site plan for location of circulation and security. Outdoor storage should be oriented towards the play fields. Provide concrete pad and appropriate driveway and sidewalk access and/or ramp to future storage container
- Provide at least one main custodial room in a central location, large enough to accommodate floor buffing machines and include (1) data and quad power receptacles, intercom (handset and speaker), telephone outlet and coat hook on back of door.
- Remote custodial rooms shall include a 24" x 24" mop sink with stainless steel backsplash, mop rack, and 24" deep metal shelving.
- One custodial room to have washer/dryer; vent dryer to exterior.
- Spaces to receive sealed concrete floor finish and CMU walls.
- Ceiling to be acoustical tile or open to structure.
- Hot and cold water, ventilation per code.
- Rooms to be lockable.
- Provide additional shelving in each Custodial Room for storage of attic stock materials, per the A/E Guide.

## **STAFF TOILETS**

### **OBJECTIVES**

To provide space for toilets facilities for staff

### **DESIGN CONSIDERATIONS**

- Staff toilet rooms should be located evenly throughout the building

### **PHYSICAL REQUIREMENTS**

- Provide ADA compliant mirror over ADA sink
- Provide a full height mirror on the wall.
- Porcelain tile floor and base
- The preference is for the door to swing out
- Provide a GFCI outlet
- Ceiling to be gypsum or scrubbable ceiling panels

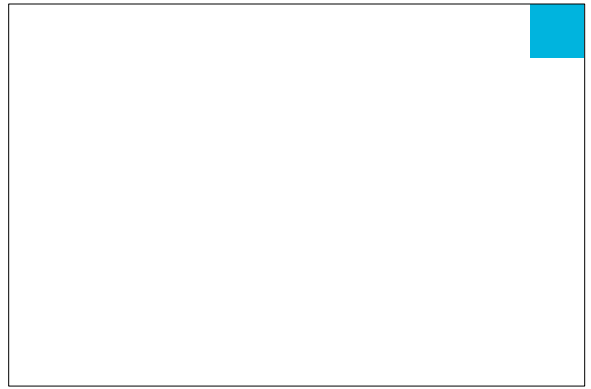

## **OUTDOOR AREA**

- Provide outside paved area with three basketball goals, typically bus lot.
- Provide two play fields (approximately 60 yds. x 110 yds.). One additional Pre-K playground to be provided on campus if Pre-K classes are incorporated into teaching curriculum for the school
- Provide two separate areas for two sets of playground equipment, each approximately 60' x 60'. One for kindergarten through second graders, the other for third through fifth graders with appropriately sized equipment. Each playground to have appropriate drainage pits and accessible paths of travel from the school
- Provide concrete pad and accessible route to Conex storage container. Container and pad to be enclosed with fencing and double gate.
- Provide one 10'-12' wide track of striped asphalt approximately 400 meters around bus lot for measured distances fitness testing
- Provide accessible routes to all play areas
- Provide fencing at areas with greater than 3 to 1 slope to prevent balls and equipment from rolling away.

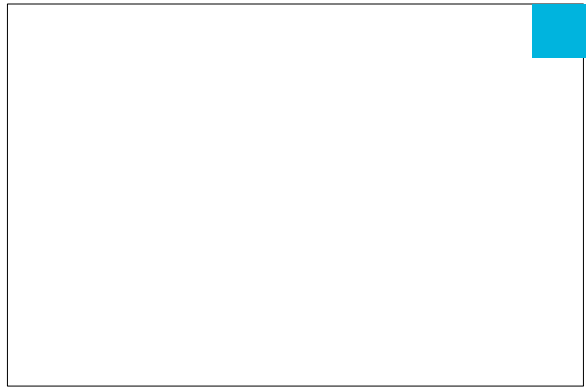

## **CORRIDOR**

- Provide a linear design integrated into Corridor VCT floor pattern to have markings for the students to use to line up in the Corridor.
- Corridors and Main Lobby shall use lay-in acoustical panels. Gypsum wallboard may be used as an accent. Consider exposed painted structure on a case-by-case basis.
- Provide an outlet at least every 50' in Corridors.
- Locate switches for Corridors in an Office, a Workroom, or a similar area not subject to student's tampering.
- Key operated switches may be appropriate in Corridors of Building Additions.
- Cable trays shall be provided in Corridors per A/E Guide.
- Bulkheads are acceptable to break up very long corridor ceilings as well to use for MEP or structural transitions from one side to another. Minimum height of bulk heads should be high enough that they do not interfere with the security camera vision down hallways to the next camera zone/location.
- Accent paint colors are acceptable in corridors if located above the door frame height to minimize future touch ups. Avoid bright colors on door frames.
- Room signage required at all doors.
- Provide 4' tack board at each classroom to allow the teacher to personalize his/her learning environment/curriculum.

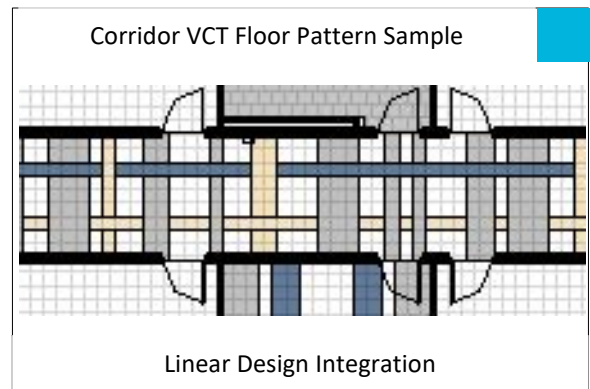

## LIST OF REVISIONS

<b>Heading</b>	<b>Page</b>	<b>Revision</b>	<b>Rev. Date</b>
1. Program of Spaces	3	Provided a breakdown of the Group Restroom 2700 SF line item.	10/04/19
2. Team Area	11	Noted to provide a copier alcove, with copier data & power reqts.	11/12/19
3. Music Classroom	21	Replaced Music Clrm. page with an updated Music/Choral Clrm. Page.	12/16/19
4. List of Revisions	1	Added List of Revisions to Facility Program for tracking changes.	03/06/20
5. Wellness Room	45	Revised ES Wellness Room to indicate single room configuration.	03/24/20
6. Gen. Clrm. - Gr. K-1 <sup>st</sup>	6	Casework Elevations revised. Cubby qty. revised from 30 to 24-26.	06/11/20
7. Gen. Clrm. - Gr. 2 <sup>nd</sup> -5 <sup>th</sup>	8	Casework Elevations revised. Cubby qty. revised from 30 to 24-26.	06/11/20
8. Resource Room	10	Casework Elevation added.	06/11/20
9. Team Area	11	Casework Elevation added.	06/11/20
10. Flex Use Room	13	Casework Elevation added.	06/11/20
11. Visual Arts Classroom	18	Casework Elevation added.	06/11/20
12. Music/Choral Classrm.	21	Casework Elevation revised.	06/11/20
13. Media Center Workroom	23	Casework Elevations added.	06/11/20
14. Makerspace	27	Casework Elevation added.	06/11/20
15. Workroom	37	Casework Elevations added.	06/11/20
16. Faculty Breakroom	39	Page added for Faculty Breakroom, with Casework Elevation.	06/11/20
17. Health Room	41	Casework Elevation added.	06/11/20
18. Parent Center	44	Casework Elevation added.	06/11/20
19. Wellness Room	45	Casework Elevation added.	06/11/20
20. Principal's Office	32	Deleted requirement for TV connection and wall bracket.	06/29/20
21. Gen. Clrm. - Gr. K-1 <sup>st</sup>	6	Casework Elevations revised; teacher's wardrobe added.	09/01/20
22. Modified Restroom	17	Casework Elevation added. Wall cabinet added above base cabinet.	09/01/20
23. Workroom	37	Casework Elevations updated.	10/26/20
24. Makerspace	27	Casework Elevation updated.	10/26/20
25. Media Center Workroom	23	Casework Elevations updated.	10/26/20
26. Modified Restroom	17	Casework Elevation updated.	10/26/20
27. Resource Room	10	Casework Elevation updated.	10/26/20
28. Health Room	41	Casework Elevation updated.	10/26/20
29. Team Area	11	Casework Elevation updated.	10/26/20
30. Flex Use Room	13	Casework Elevation updated.	10/26/20
31. Parent Center	44	Casework Elevation updated.	10/26/20
32. Wellness Room	45	Casework Elevation updated.	10/26/20
33. Faculty Breakroom	39	Casework Elevation updated.	10/26/20
34. Visual Arts Classroom	18	Arch. Criteria and FF&E updated. Casework Elevations updated.	10/26/20



<b>35. Media Center</b>	23	Media desk details added.	11/16/20
<b>36. Team Area</b>	11	Refrigerator added (to be included in GC contract)	02/10/21
<b>37. Health Room</b>	41	Mini-fridge indicated to be ADA, and included in GC contract	02/10/21
<del><b>38. Music/Choral Room</b></del>	<del>21</del>	<del>Music equipment/instrument list by Owner added to Appendix</del>	<del>02/15/21</del>
<b>39. Corridor</b>	54	Page added for Corridors	03/22/21
<b>40. Music/Choral Room</b>	21	Note added for Owner to provide current "Perf. Arts Equip. List"	06/25/21
<b>41. MultiPurpose Room</b>	28	Changed climbing wall reference; deleted 15' high ceiling in Stor. Rm.	09/03/21
<b>42. Student Records</b>	40	Noted to be adjacent to Student Services and Fin. Secretary Offices	11/02/21
<b>43. Reception/Sec's. Area</b>	30	Noted to provide space for 2 work stations behind counter	11/02/21
<b>44. Cafeteria and Kitchen</b>	47	Added electric water cooler with bottle filler in Dining Area	12/03/21
<b>45. Custodial Rooms</b>	51	Shelving added for attic stock materials storage per A/E Guide	12/03/21
<b>46. Media Center</b>	23	Deleted Conference Room from Media Center	01/20/22
<b>47. Wellness Room</b>	45	Clarified under-counter refrigerator to be by Contractor	06/20/22
<b>48. Modified Restroom</b>	16	Updated grab bar length, lockset indicator, changing table type	07/25/22